



ASSOS | ASSOS OVEN
ENERGY EFFICIENT WOODSTOVE



**INSTALLATION
& USER MANUAL**



Table of contents

1. Arte® Wood stove - A Greek Quality Product.....	2
2. Facts about wood and the environment.....	2
2.1. Why use wood?	2
2.2. Buying firewood.....	2
2.3. Storing your wood	2
2.4. Wood types and calorific value	3
2.5. Determining the heat output.....	4
3. Endorsements & Certifications	5
3.1. Endorsement.....	5
3.2. Declaration of Performance CE	5
3.3. Features marking plate	5
4. Packaging	5
4.1. Unpacking the stove	5
5. Fire safety	6
5.1. Safety distances	6
5.2. General security instructions	6
5.3. Flue security instructions	6
5.3.1. Basic requirements for proper flue operation.....	6
5.3.2. Chimney placement	7
5.3.3. Chimney cap.....	7
5.3.4. Malfunction - Secure woodstove shutdown	7
6. Operating Instructions.....	8
6.1. Before initial use of an ARTE® ASSOS woodstove	8
6.2. About ARTE® ASSOS woodstove	8
6.3. General information	8
6.3.1. When the woodstove paint dries	8
6.3.2. Incineration preparation.....	8
6.3.3. Heating during seasonal change or in adverse weather conditions.....	8
7. Igniting the stove	9
7.1. Traditional method of igniting.....	9
7.2. Igniting without CO emissions (TOP TO BOTTOM)	9
8. Tertiary combustion	10
9. Cleaning & Maintaining the Woodstove	10
9.1. External maintenance	10
9.2. Internal maintenance	11
9.2.1. Ash disposal	11
9.2.2. Glass	11
9.2.3. Gasket.....	11
9.2.4. Internal parts that need maintenance	11
9.3. Cleaning the woodstove and the flue.....	12
9.3.1. Chimney sweeping	12
9.3.2. Annual maintenance	12
9.3.3. How to clean the inside parts of ARTE® ASSOS woodstove.....	12
9.4. Internal parts removal	13
9.5. Inactive fireplace for prolonged periods	13
10. Tips & Tricks for Resolving Issues	13
11. Dimensions.....	14
12. Technical Specifications.....	16
13. Warranty	17
13.1. Warranty terms.....	17
13.2. Excluded from the warranty	17
13.3. Responsibility.....	17
13.4. Emergency maintenance	17
13.5. Responsibility for installation.....	17
13.6. Usage	17
13.7. Legal guarantee.....	17

1. ARTE® WOOD STOVE - A GREEK QUALITY PRODUCT

Thank you for buying an ARTE® wood stove - we believe that you will have as much pleasure from our product as we have.

Your ARTE® wood stove is made in such a way, to extract the maximum possible energy from the wood with the minimum possible emissions, using the most innovative technology and the most robust design - made in Greece!

These instructions contain interesting and informative facts and all you need to know about the subjects of heating, wood, and operating your ARTE® wood stove. Please read these instructions carefully before using your wood stove for the first time and keep them in a safe place.



The manuals which are enclosed with the product must be kept throughout the product's entire service life.

2. FACTS ABOUT WOOD AND THE ENVIRONMENT

2.1. Why use wood?

With proper forest management, burning wood does not deplete the earth's resources. Heating with wood usually does not contribute to global warming. The young trees that replace the trees in your wood stove absorb carbon dioxide from the air. Burning firewood releases only as much CO₂ as the tree has absorbed from the atmosphere during its growth. Wood rotting in the forest generates the same amount of CO₂ as the same wood burning.

Besides being environmentally friendly, the heat from a wood stove warms you like the warming rays of the sun during the sunny winter days. It is the radiated heat that transmitted by electromagnetic waves in the infrared range. Even when the air is very cold you can feel the warm rays of the sun on your skin.

Another advantage to wood is that it is produced locally, which creates local employment, and more tax revenues stay in the province.

2.2. Buying firewood

Where can I get my firewood?

Regenerated ready-to-burn firewood can be purchased from dealers:

- ① Wood stove ready, stored for at least two years
- ① Pre-dried, stored for one year
- ① Fresh from the forest

Whether you have cut your own wood or bought it, the important thing is: **the wood should be dried for at least two years before it is burned.**



The ideal residual moisture is 12 - 15% and should be no higher!

2.3. Storing your wood

The full potential for heat will not be realized if you neglect the simple chore of piling and protecting your wood. Proper storage is essential to avoid moisture, bacteria, and insect problems in your home.

To avoid problems with insects and moisture, store the wood as far from your house as is practical. Do not store wood in your basement; one cord of wood can give off more than 500 liters of water. The basic rule is to hide the wood from water, but not from the sun or wind (**Pic. 2.3.1 & 2.3.2**) Green wood will dry slowly or not at all if unprotected, while seasoned wood left unprotected may become unseasoned.

There are three basic rules to follow when storing wood:

- ① Allow air circulation by piling one tier wide if possible
- ① Protect wood from rain and snow by covering with a tarp or woodshed roof.
- ① Pile wood off the ground on scrap lumber or wooden pallets.

The time-honored way to cure wood is to buck, split, and stack wood off the ground for one full year. How-ever, wood can generally be reduced to 20 per cent moisture content in two to three months. The ideal 10% to 15% may take longer (almost 18 months).

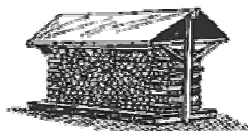
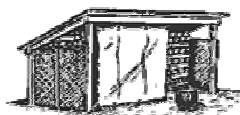

Pic. 2.3.1



Pic. 2.3.2



2.4. Wood types and calorific value

A wood's efficiency does not depend only on its type, but also on its humidity, as well as the temperature of the combustion chamber.

For more efficient and longer burning, without emission of hazardous substances, woods must be dry. Ideally, their humidity percentage must not exceed 10% to 15%.

If this percentage is over 20%, the wood is not burned properly, whereas if the piece of wood has been cut recently, the humidity is over 60% making it unsuitable for burning. The reason for that is that the fire will be weak and pale and will produce dense smoke, unburned tar and creosote, soiling the ceramic glass and the flue.

It is preferable to get your wood supplies during the summer months and store them, to ensure better combustion quality during the winter.

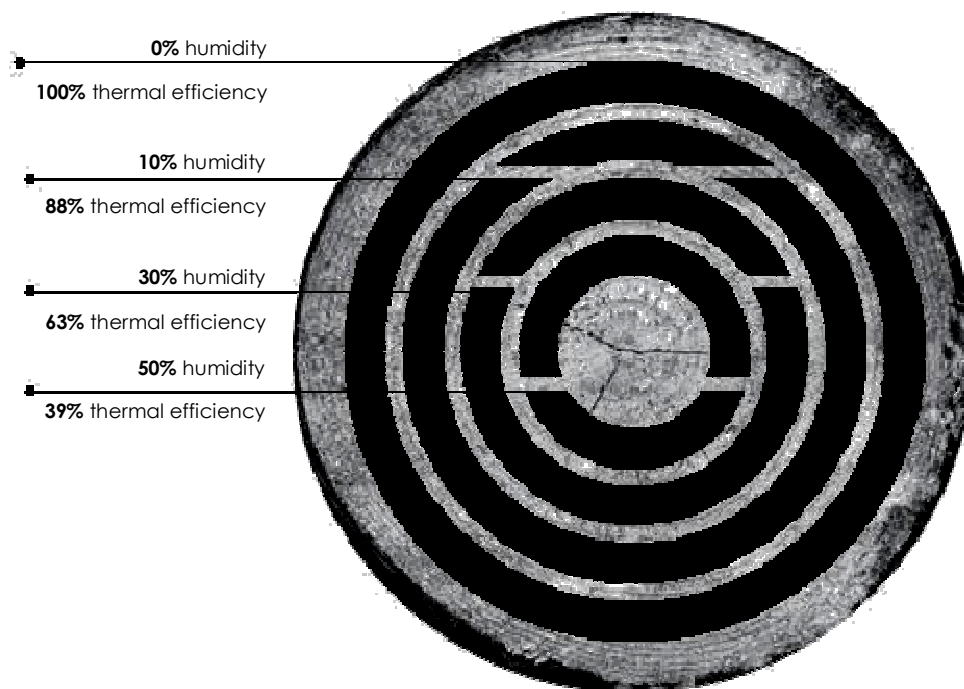

Useful tips

- ① Always choose dry firewood.
- ① Avoid wood that pops (chestnut, conifers such as cedar, spruce and pine), as they may damage your wood stove or the flue.
- ① Pay attention to the size of the logs. Good firewood must have been cut at least twice.
- ① You should prefer oak, beech, olive wood, which is hard wood with high density since they will burn for longer.

Briquettes

They ignite very easily, and burn slowly. They are economically advantageous because you will burn smaller quantities compared to common firewood and they are easily stored. Also, you have less quantity of ashes vs. to wood.

Birch

It's a soft wood that ignites easily with great thermal energy production. It produces less smoke and ash compared to other wood and burns silently. The same characteristics apply for lime and chestnut.

Beech

Hard wood is ideal for firewood but requires a high temperature to ignite. It weights a lot; it is dense and burns with a calm and long fire for a longer time. Best when well seasoned. The same applies for oak, but seasoned for 2-3 years.

The various wood types have various calorific values

Wood type	Thermal capacity (Kcal/h-1Kg)
Briquette	5.000
Birch	4.800
Walnut	4.731
Oak	4.619
Beech	4.578
Fir	4.588
Common Oak	4.548
Pine	4.457
Olive	4.100
Poplar	4.022



Table 2.4.1

$860\text{Kcal/h} = 1\text{ kW/h}$

The values are based on 15% residual wood moisture.



An ARTE® wood stove can be fired with all of the above wood types

2.5. Determining the heat output

There is not a specific rule that enables the calculation of the required heat output. This depends on the amount of space that is required to be heated and mostly on its insulation. In average the required heat output for a properly insulated room and with external temperature of 0° is 40 kCal/h per m³.

Taking into account that 1kW equals 860 kCal/h an equivalent of 50W/m³ can be used. For example, to heat a 50 m³ room (10 x 6 x 2.5m) in an insulated residence, the output required is 150m³ x 50W/m³ = 7500W or 7.5 kW.

So for the main heating, a 10kW appliance is enough.

Fuel	Unit	Indicative combustion value with efficiency ~80%		Required amount relative to 1kg dry wood
		kCal	kW	
Firewood (moisture 15%)	kg	3600	4.2	1.00
Firewood (moisture 50%)	Kg	1850	2.2	1.95
Wood briquettes	Kg	4000	5.0	0.84
Coal briquettes	Kg	4800	5.6	0.75
Coal	Kg	7700	8.9	0.47
Coke	Kg	6780	7.9	0.53
Gas	m³	7800	9.1	0.46
Diesel	L	8500	9.9	0.42
Electricity	kW/h	860	1.0	4.19

Table 2.5.1

3. ENDORSEMENTS & CERTIFICATIONS

3.1. Endorsement



The ARTE® wood stove you chose has been tested according to **EN13229**.



3.2. Declaration of Performance CE

The constructor G. Karnoutsos & Co. declares that ARTE® wood stoves meet the requirements of the standard **EN 13240**, also the product's performance according to the quality specifications are monitored on a permanent basis.

3.3. Features marking plate

ARTE® wood stove's feature marking plate is located on the right side of the appliance.

	ASSOS CH02 v9 EN 13240:2001 Wood Stove	
ASSOS		
Global thermal power (yield):	13371 Kcal/h – 15,54 kW	
Global efficiency:	78,73 %	
CO emissions at 13% O₂:	0,2615 %	
Smoke temperature:	248 °C	
READ AND FOLLOW THE OPERATING INSTRUCTIONS		
USE ONLY RECOMMENDED FUELS		
MINIMUM SAFETY DISTANCE FROM FLAMABLE MATERIALS: 80 cm		
INTERMITTENT OPERATION DEVICE		
DO NOT USE IN SHARED FLUE		
SERIAL NUMBER: XX XX XX XXX XX XXXX		
KARNOUTSOS G. & CO (O.E.) Phone: (+30) 2310 684148 Fax: (+30) 2310 684149 Pr. Makrigiani, Evosmos Thessaloniki Greece Postal Code: 56410		

	ASSOS OVEN CH01 v9 EN 13240:2001 Wood Stove	
ASSOS OVEN		
Global thermal power (yield):	13283 Kcal/h – 15,44 kW	
Global efficiency:	80,74 %	
CO emissions at 13% O₂:	0,2564 %	
Smoke temperature:	248 °C	
READ AND FOLLOW THE OPERATING INSTRUCTIONS		
USE ONLY RECOMMENDED FUELS		
MINIMUM SAFETY DISTANCE FROM FLAMABLE MATERIALS: 80 cm		
INTERMITTENT OPERATION DEVICE		
DO NOT USE IN SHARED FLUE		
SERIAL NUMBER: XX XX XX XXX XX XXXX		
KARNOUTSOS G. & CO (O.E.) Phone: (+30) 2310 684148 Fax: (+30) 2310 684149 Pr. Makrigiani, Evosmos Thessaloniki Greece Postal Code: 56410		

4. PACKAGING

ARTE® is devoted in protecting the environment, so we use as much recyclable materials as possible and the least amount of packaging materials without compromising the secure transfer of our products.

4.1. Unpacking the stove

1. The product is delivered on a wooden palette. **(Pic. 4.1.1)**
2. Carefully remove the plastic membrane and the waterproof plastic film and also all the styrofoam on the outside and inside of the product.
3. Remove the styrofoam that is on the upper part of the baffler in ASSOS and on the back in ASSOS OVEN and also in the combustion chamber and the ashtray, including any other components. **(Pic. 4.1.2)**
4. Unscrew the 4 screws located on the bottom side of the product, in order to release the stove from the palette. **(Pic. 4.1.3)**
5. Carefully pick up the product and place it on the installation point, making sure that the floor can withstand the weight of the device. If the existing construction cannot withstand the weight of the device, a load distributing plate is necessary. Also, make sure you provide proper insulation in case the floor is built using flammable materials.

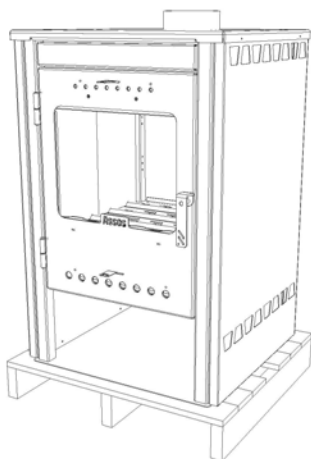

Pic. 4.1.1

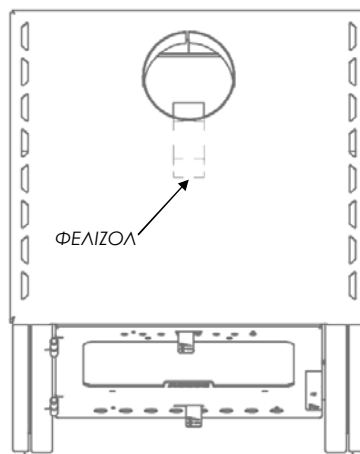

Pic. 4.1.2

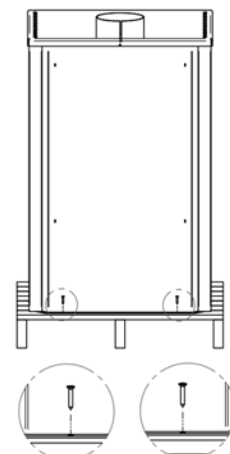

Pic. 4.1.3

5. FIRE SAFETY

It is **OBLIGATORY** to respect the National and European rules and local regulations concerning building matter and fireproof rules.

The installation **MUST** be inspected by a qualified auditor, prior to lighting the woodstove. Also the appropriate local authorities must be informed.

5.1. Safety distances

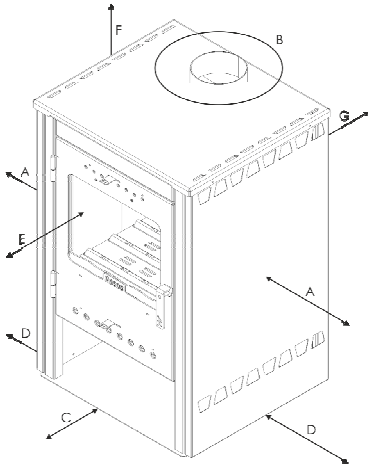

Safety distance A

The side panels must be at least 25cm away from any flammable materials, like furniture, clothes etc.

Safety distance B

The flue pipes must be at least 25cm away from any flammable materials.

Safety distance C + D

Any flammable materials on the floor must be at least 50cm from the front (distance C) and 30cm from the sides (distance D) of the stove.

Safety distance E

The combustion chamber opening must be at least 80cm away from any flammable materials that are inside the heat radiation zone.

Safety distance F

The minimum distance from the ceiling must be 60cm.

Safety distance G

The back must be at least 25cm away from any flammable materials, like furniture, clothes etc.

5.2. General security instructions

- ⓘ Never leave children alone or without supervision near the woodstove when it is lit.
- ⓘ Teach children how to operate the woodstove correctly and safely.
- ⓘ Never touch the external surfaces of the woodstove or the glass when it is lit. There is a high risk of burns!
- ⓘ Due to the self closing door, you have to be extra careful when you are filling the woodstove.
- ⓘ It is forbidden to use the woodstove as a waste incinerator.
- ⓘ Don't use burned or used wood as fuel.
- ⓘ Remove the ash only after it has completely cooled off.
- ⓘ Ash should be placed outdoors or be disposed in a place where there is no risk of ignition.
- ⓘ Immediately inform your specialized local supplier if you find any malfunction.
- ⓘ Don't use chemicals or liquids as fire starters.
- ⓘ Do not use ANY fuel other than the recommended.



Follow the operating instructions supplied with the product to help prevent fire and protect the environment.

5.3. Flue security instructions

Prior to installing the woodstove ARTE® the chimney sweep or a qualified technician should check the condition and operation of your chimney in accordance with the standards **EN13384-1** & **EN13384-2**.

This way you ensure the best conditions for heating without issues.

5.3.1. Basic requirements for proper flue operation

- ⓘ The internal section of the flue must preferably be circular. In a case of square or rectangular flue, the internal corners should have a radius of at least 20mm. In case of rectangular flue, the ratio of the sides should be at maximum 1: 1.5.
- ⓘ The flue must be properly insulated and waterproof and constructed of materials with thermal resistance and resistance to combustion products and any deposits.
- ⓘ The flue must have no constrictions; it must have a vertical path and it should not change in direction that exceeds 45°. (Pic. 5.3.1.1)
- ⓘ In case of an existing flue the construction material should be checked. Materials such as cement with lime, galvanized steel and rough or porous materials are contraindicated as they create issues in the correct operation of the woodstove. Also, a proper study for the flue size must be conducted because often old flues have quite large diameters. This means that the amount of air draft is not proportional to the heat generated by the woodstove and by extension means that you consume more wood than necessary and will spend more time on maintenance. The solution proposed in these cases is the connection of an inner tube inside the flue. This tube should extend over the whole length of the flue and at no point should exceed in diameter the outlet flue of the woodstove. If the existing flue has the desired diameter a proper cleaning by qualified personnel should be done.

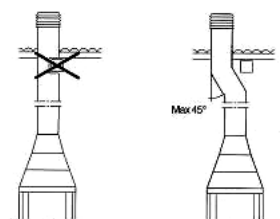

Pic. 5.3.1.1

❶ Inserting the pipe along the outer wall must be properly studied to avoid heat loss. This solution, however, is contraindicated, as positioning the flue inside the house warms more spaces as heat of the flue remains in the house.

5.3.2. Chimney placement

The placement of the chimney on the roof is a particularly decisive factor in the convection of the woodstove.

An incorrectly fitted chimney may generate reimbursement of exhaust into the heating space due to down flow of the air.

Follow the instructions below to ensure proper dissipation of smoke. (Pic. 5.4.2.1)

- ❶ The ending of the chimney must be at least 50cm above the top of the roof.
- ❶ If there is more than one chimney on the roof, they must be positioned at least 2m apart.
- ❶ If there are two adjacent chimneys, their ends must be at least 50cm apart.

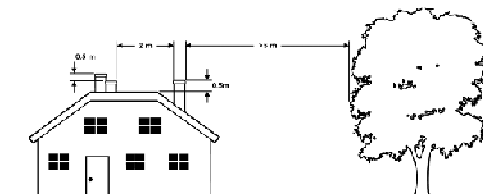

Pic. 5.3.2.1

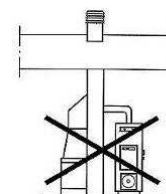

Pic. 5.3.2.3

- ❶ If there is a tall building or tree next to the house, then you should place the chimney at a distance greater than 5m from the obstacle.
- ❶ It is prohibited to connect several devices to the same chimney. Every chimney should be autonomous. (Pic. 5.4.2.2)
- ❶ In case of an inclined roof, the height of the chimney is defined depending on the inclination and the distance of the chimney from the ridge according to the following table. (Pic. 5.4.2.3)

Inclination α°	RIDGE – CHIMNEY DISTANCE	MIN HEIGHT ABOVE THE RIDGE
	A (m)	H (m)
15°	< 1,85 m	0,50 m OVER THE RIDGE
	> 1,85 m	1,00 m OVER THE ROOF
30°	< 1,50 m	0,50 m OVER THE RIDGE
	> 1,50 m	1,30 m OVER THE ROOF
45°	< 1,30 m	0,50 m OVER THE RIDGE
	> 1,30 m	2,00 m OVER THE ROOF
60°	< 1,20 m	0,50 m OVER THE RIDGE
	> 1,20 m	2,60 m OVER THE ROOF

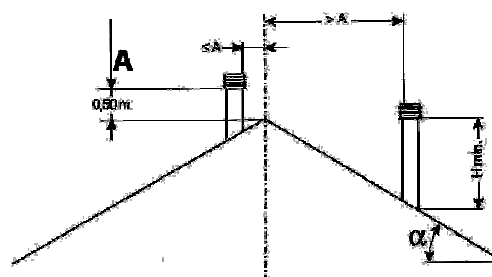

Pic. 5.3.2.3

5.3.3. Chimney cap

The chimney draft depends broadly on the adequacy of the cap.

So, in case the chimney is built, its exhaust diameter should be at least twice the inside diameter of the chimney. Knowing that it is necessary to protrude from the ridge of the roof, the cap must ensure the proper smoke dissipation in case of strong wind.

A chimney cap must meet the following requirements:

- ❶ Internal diameter must be equal to the diameter of the chimney.
- ❶ Exhaust diameter be at least twice the inside diameter of the chimney.
- ❶ It should be constructed in such a way as to avoid the entrance of rain, snow and any foreign body in the chimney.
- ❶ It can be checked, maintained and cleaned easily.



Industrial style cap with protective net.



Cap with fan. It provides very good smoke dissipation even in case of weak winds



Cap with deflector. It leans according to the wind and it provides very good smoke dissipation

5.3.4. Malfunction - Secure woodstove shutdown

In rare occasions even a test fire may not cause sufficient draft in the flue. In this case contact your chimney sweep.

Under no circumstances should you try to light a larger fire. If smoke escapes from the woodstove, ventilate the room immediately and contact your chimney sweep. **DON'T LIGHT THE WOODSTOVE!**

6. OPERATING INSTRUCTIONS

6.1. Before initial use of an ARTE® ASSOS woodstove

One of our qualified dealers has already given you instructions on how to operate the ARTE® ASSOS woodstove you just bought.

In the guidelines below there are detailed instructions on the steps to follow so you do not encounter any issues during the operation of the woodstove.

The qualified dealer in your area is at your disposal to answer any of your questions. The ARTE® ASSOS woodstove is equipped with the following control systems:

6.2. About ARTE® ASSOS woodstove

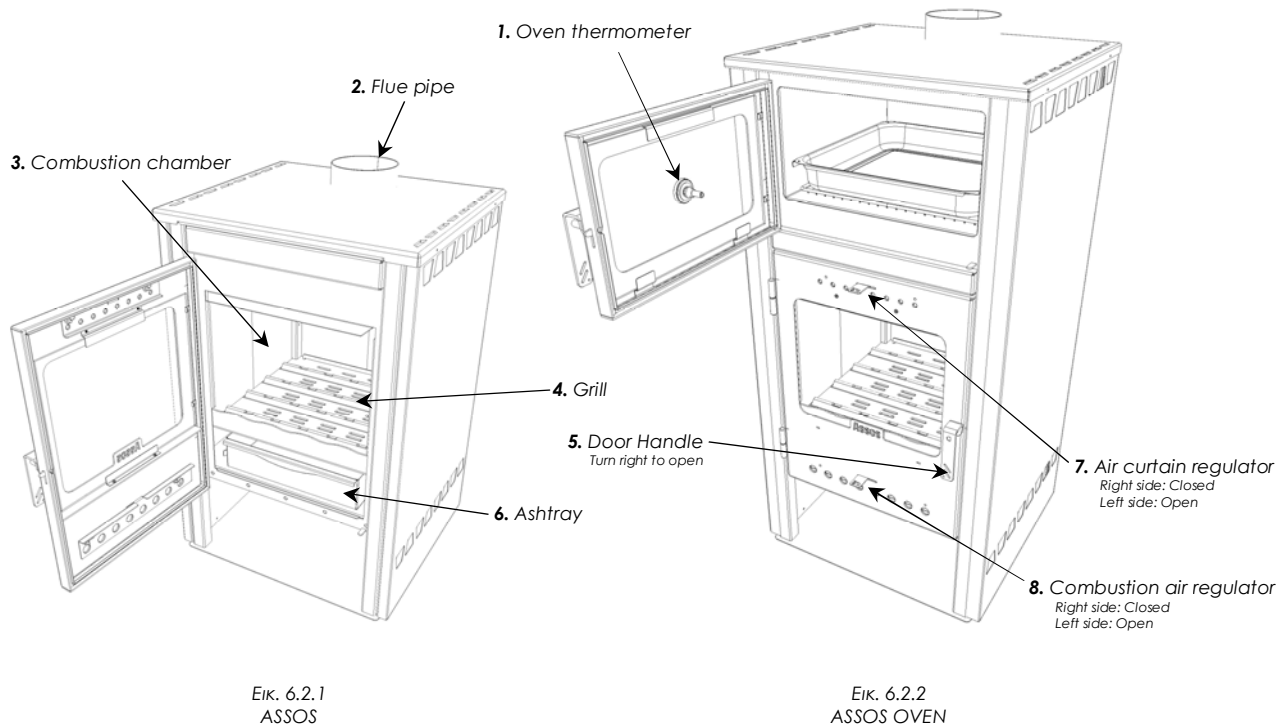

The woodstove you just received is a device that is designed to offer you optimal heating distribution in your area with very high efficiency.

6.3. General information

6.3.1. When the woodstove paint dries

ARTE® products are painted in spray booth with as more environmentally friendly and ecological colors as possible. There is although a possibility that the first few times the woodstove is lighted, the paint emits an odor. Let the fire burn with intense convection until all traces of gas disappear and there is no longer a smell. The gas is not toxic, but the room should be well ventilated.

6.3.2. Incineration preparation

Prepare sufficient amount of chopped firewood, kindling and branches or torches. Before using the wood it is recommended to store them in a warm place for a few days.

6.3.3. Heating during seasonal change or in adverse weather conditions

When humidity is high or there is fog, with temperatures ≥ 15 ° C, but also during the transitional period between seasons, it is recommended to light a test fire before normally lighting the woodstove. This will displace the cold, heavy air that is inside the flue and create the right conditions for optimum smoke dissipation.



Under no circumstance should you operate the woodstove with the main door open. You run a serious risk of destroying the device.

7. IGNITING THE STOVE

7.1. Traditional method of igniting

Every time you ignite the stove, it initially needs a large amount of air. If the stove is cold, leave the door slightly open or secure the handle on the first latch, in order for air to circulate around it for the first minutes of ignition. Also you must fully open the primary and secondary combustion air supplies.



**Do not leave the stove unattended while the door is open.
Be very careful during the fueling of the woodstove.**

To form an adequate layer of ash at the base of the woodstove, use 1-2 kg of dry kindling the first time you ignite it. If it is possible, constantly maintain a layer of ash with thickness of 2-3 cm at the base of the combustion chamber for added insulation.

1. Put 2-4 fuel tablets or 7-10 rolled up sheets of newspaper underneath 1-2 kg of dry kindling. (Pic. 7.1.1)
2. Open the primary (Pic. 6.2.1, Point 7) and aircurtain (Pic. 6.2.1, Point 6) air supply in the maximum level by pulling the regulators out.
3. After the fuel tablets/rolled up sheets have ignited, leave the door slightly open, in order to ensure an adequate convection of the flue.
4. Once you ensure the flue is warm enough (after 5-10 minutes), close the door. If all required conditions are met, after 15-20 minutes a thick layer of cinder will be formed in the combustion chamber and the temperature will rise, which is essential for the continuation of combustion.
5. Once the requirement described in point 4 is met, place 2-3 logs with overall weight of 1.5-3kg, depending on the size of the woodstove, on the cinder, with a distance of about 1cm from one another.
6. Open the primary combustion air supply to the maximum level and close the door. The wood will begin to burn within 2-3 minutes. If not, open the door slightly in order for enough air for combustion to enter. Once the wood ignites close the door again and also the primary combustion air supply.
7. Adjust the regulator of the air curtain air supply to the desired position in order for the optimal combustion to continue. Make sure that there is always enough air (oxygen) to maintain clear, lasting flames when, and after, reducing the amount of combustion air.
8. Once the fire has been reduced to a thick layer of embers, a new portion of wood can be added by repeating steps 5-7.



In order to avoid soot on the glass, it is important that the logs are not placed adjacent to the glass of the door.

7.2. Igniting without CO emissions (TOP TO BOTTOM)

1. Open the primary (Pic. 6.2.1, Point 7) and aircurtain (Pic. 6.2.1, Point 6) air supply in the maximum level by moving the regulators to the right. If needed, leave the door slightly open.
2. Place 2-3 logs with a total weight of 1.5-3 kg and a length of 30-35 cm on the bottom of the combustion chamber.
3. Put 2-3 fuel tablets or 5-8 rolled up sheets of newspaper between the logs.
4. Add some kindling wood (1-2 kg) in a criss-cross pattern on top. (Pic. 7.1.2)
5. Finally, place a medium-sized log on the top of the pile and light the tablets/newspaper.



The openings of the secondary air supply should not be covered by firewood.

6. Once you ensure the flue is warm enough (after 5-10 minutes), close the door.
7. Adjust the regulator of the aircurtain air supply to the desired position in order for the optimal combustion to continue. Make sure that there is always enough air (oxygen) to maintain clear, lasting flames when, and after, reducing the amount of combustion air.
8. Once the fire has been reduced to a thick layer of embers, a new portion of wood can be added.

Feed the woodstove often but with small amounts of firewood, at most 1.5-4.8kg, depending on the size of the woodstove, each time. If the woodstove is overly full, the generated heat may cause excessive strain on the flue. The supply of firewood should be done in moderation.

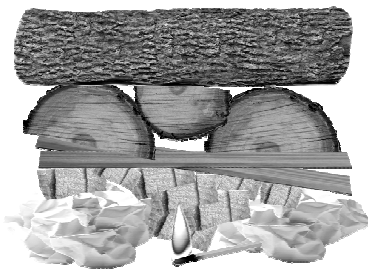

Pic. 7.1.1

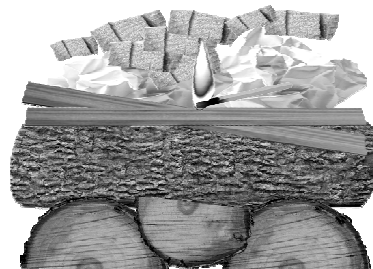

Pic. 7.1.2



The fire should be vigorous and the smoke exiting from the flue must be almost unnoticeable.

The fire should not be smoldering because it is causing more pollution.

If the door remains slightly open, fire gases and flames may escape from the opening of the woodstove causing a risk of fire or asphyxiation. We recommend installing a smoke detector in the room where the woodstove is located.

Under no circumstance should you operate the woodstove with the main door open. You run a serious risk of destroying the device.

DO NOT OVERHEAT THE WOODSTOVE! There is risk of fire or permanent damage. If any part of the woodstove starts glowing, then the device is overheating.

Wood combustion rules

- ① If you want less heat, put a smaller quantity of wood in the woodstove and reduce the amount of air. It is however important to maintain an adequate layer of cinder.
- ① Less heat = Less wood = Less air.
- ① More heat = More wood = More air.
- ① When the woodstove operates at excessively low power or if the wood is not sufficiently dry, soot might deposit on the glass.

8. TERTIARY COMBUSTION

The two combustion points

The combustion of wood requires a process of primary, secondary, and tertiary combustion to be efficient.

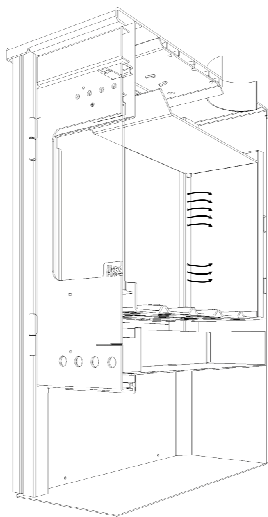

Eik. 8.1.1

1. Primary combustion

Primary combustion is the initial wood burning at relatively low temperatures. During the primary combustion, large amounts of soot, creosote and gas are produced due to the existence of water in the wood. Creosote, in primary combustion, contains 60% of the potential energy of wood, but it is deposited in the form of soot inside the woodstove and the flue without imparting any heating.

2. Secondary combustion

The combustion chamber is insulated so as to increase the temperature of the core and by providing just the right amount of oxygen necessary to 600°C, the creosote ignites spontaneously. This creates a chain reaction that increases the temperature inside the woodstove from 600°C to about 870°C without having to add any more fuel. This is the secondary combustion.

Thereby, the more proper secondary combustion is achieved the higher temperatures are produced and the less residue is left (gas and particles). The vast majority of secondary combustion is only done in the upper part of the chamber near the outlet of the flue. Thus a large part of the heat that is achieved, is discharged directly through the draft of the flue to the exterior and not in the heating area.

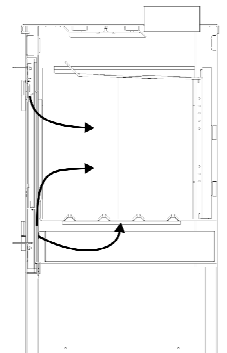

Eik. 8.1.2

ARTE's® combustion chamber manages to provide the maximum secondary combustion performance. The air intake regulating system in cooperation with two vertical ducts having openings (Pic. 8.1.1), in such a way as to insert the appropriate amount of hot air through the entire length of the pipeline, onto the calcined side of the combustion space and the aircurtain of the ceramic glass, results in the fire receiving the right amount of preheated oxygen throughout the combustion chamber (Pic. 8.1.2, Pic. 8.1.3). This way the whole area of the chamber is converted in a secondary combustion chamber, not only the upper part, and thus its performance dramatically increases and inversely gas residue reduces.

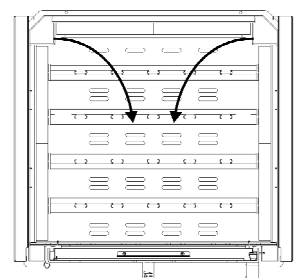

Eik. 8.1.3

9. CLEANING & MAINTAINING THE WOODSTOVE



When performing maintenance on the woodstove, always protect yourself, using safety goggles and gloves

9.1. External maintenance

The stove surface is painted with heat-resistant paint. It is best kept clean by vacuuming with a soft brush attachment or by wiping with a lint-free cloth. Over a period of time, the painted surface may become slightly grey. A canister of touch-up ARTE® spray paint should be available from your woodstove supplier. This can be applied - in accordance with the instructions - in just a few minutes. When first firing, after touching up, the woodstove will give off a slight smell as the paint cures. Make sure to ventilate the room well during this phase.

9.2. Internal maintenance

9.2.1. Ash disposal

Empty the ash pan on a daily basis or as needed. Ash allowed to build up towards the underside of the grate will trap heat and could cause premature failure of the grate.

Empty the ash pan according to this procedure:

- ① Open the front door, and use a shovel or poker to stir excess ash through the ash slots in the grate down into the ash pan.
- ① Take out the ash pan, making sure to keep it level to avoid spilling ash.
- ① Dispose the ash in a metal container with a tight fitting lid.

The closed container of ashes should be placed on a noncombustible floor or on the ground, well away from all combustible materials, pending final disposal. If the ashes are disposed of by burial in soil or otherwise locally dispersed, they should be retained in the closed container until all cinders have thoroughly cooled.



Never empty a stove in operation.
Never use your household or shop vacuum cleaner to remove ash from the stove.
Always remove and dispose of the ash properly.

9.2.2. Glass

If the stove generally runs at the correct temperatures, there should be little or no dirt on the glass. If dirt does settle during lighting, most will burn off as temperatures increase.

For normal cleaning, moisten a paper towel with warm water and add some ash from the combustion chamber. Rub it over the glass and then clean the glass with clean water and dry it well. For heavier deposits that cannot be cleaned, use glass cleaner, applied when the glass is cold, in accordance with the instructions.

Never use abrasive cleaners on the glass surface.

Reasons for the presence of dirt on the glass

- ① Firewood is too wet
- ① Logs are too large or not split
- ① Combustion temperatures are too low



To reduce the risk of breaking the glass, avoid striking the glass or slamming the door.
Replace broken glass IMMEDIATELY.
Do not operate the woodstove if the glass in the door is damaged.

If there is a need to replace the glass, it should be replaced with the high temperature ceramic glass supplied by ARTE®. For more information, please contact your local ARTE® dealer.

9.2.3. Gasket

The gasket around the perimeter of the door may harden over a period of time. It should be replaced if it becomes difficult to close the door or if air starts to leak in around the perimeter of the doors, causing the fire to become a little less controllable. An ARTE® rope gasket kit is available on your local ARTE® dealer.

9.2.4. Internal parts that need maintenance

The components that are in the flame route - consisting of the firerbricks, the ceramic glass and stell baffle - are subject to extreme stress because of the heat produced by the fire. Occasionally, some of these parts may have to be replaced as part of routine maintenance.



Components in the flame route, the gasket and the paint finish are not covered by the warranty.

All of these service parts can be bought from your ARTE® dealer, and we recommend that damaged parts are replaced as soon as possible to avoid consequential damage.

Should the baffle be distorted by overheating, the woodstove will still function, although its efficiency may be compromised. Please replace it as soon as possible.

Internal wear accelerating factors

- ① Regular overheating
- ① Accumulated soot and ashes

9.3. Cleaning the woodstove and the flue

When wood is burned slowly, it produces tar and other organic vapors, which combine with emitted moisture to form creosote. The creosote vapors condense in the relatively cool chimney flue. As a result, creosote residue accumulates on the flue lining. When ignited this creosote makes an extremely hot fire.

Initially, do a monthly check for the presence of soot above the steel baffle and around the outlet flue. If the woodstove suddenly start operating slowly check for intense presence of soot in the flue / chimney.



The flue should be inspected at least once every two months during the operating season to determine if a creosote buildup has occurred. If creosote has accumulated, it should be removed to reduce the risk of a chimney fire.

Clean the flue/chimney all the way from the woodstove to the flue end point above the house. A good practice is to clean the flue after each operating season and to inspect it prior to the start to ensure that bird's nests or other blockages have not occurred during the off season.

9.3.1. Chimney sweeping

- ① Inspect the woodstove regularly during the operating season as part of a regular maintenance schedule.
- ① To inspect the chimney, let the woodstove cool completely. Then inspect the chimney through the flue collar by using a mirror. If you cannot inspect the flue system this way, the woodstove must be disconnected to provide better viewing access
- ① Clean the chimney using a brush with the same size and shape as the flue. Run the brush up and down the flue, causing any deposits to fall to the bottom of the woodstove where they can be removed the same way as the ash.
- ① If you cannot inspect or clean the chimney by yourself, contact your local ARTE® dealer or a professional chimney sweep.

If you experience a chimney fire, act promptly and:

- ① Close the air regulation
- ① Evacuate the house
- ① Call the Fire Department

9.3.2. Annual maintenance

Before the operating season starts, perform a thorough cleaning, inspection and repair:

- ① Thoroughly clean the chimney and flue connector
- ① Inspect the chimney for damage and deterioration. In case of prefabricated chimney, replace any weak sections. In case of a masonry chimney, have a mason make any needed repairs
- ① Check the ceramic glass for any cracks and replace if needed
- ① Check the door and handle for tightness. Adjust if needed.

9.3.3. How to clean the inside parts of ARTE® ASSOS woodstove

During the annual visit of your local chimney sweep and during the cleaning of internal parts of the woodstove, it is recommended to remove all internal parts of the combustion chamber to be also cleaned. **(Κεφάλαιο 9.4)**



Maintenance on the woodstove must be done ONLY when the device is

9.4. Internal parts removal

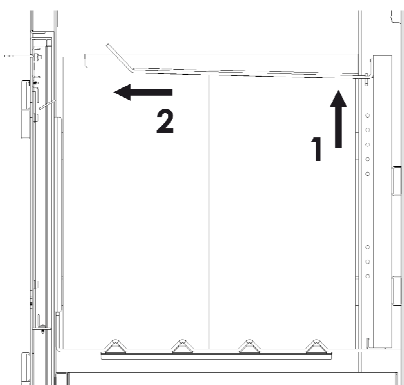

Steel baffle removal in ASSOS

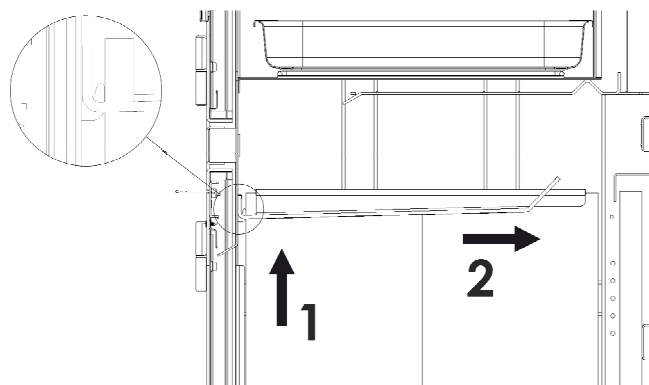

Steel baffle removal in ASSOS OVEN

9.5. Inactive fireplace for prolonged periods

IMPORTANT NOTICE: If the woodstove is not used for some time, clean it thoroughly and let the air control layout slightly open in order to let the air circulate. Ensure that the rainwater cannot infiltrate from the flue. Place a chimney cap that does not completely block the flue.

These actions should ensure there is a slight movement of air through the woodstove, and that the body and combustion chamber remain dry, right into the corners.

Ash that remains in the woodstove, when not in use, can absorb moisture like blotting paper. If moisture settles inside the woodstove, it forms rust which expands the more it settles. This can cause excessive pressure on the woodstove joints, thus causing damage.

NOTE: It is recommended to thoroughly clean the woodstove at the end of the operating season. Adding desiccant in the combustion chamber, such as cat litter, helps absorb moisture during the summer. Make sure to remove it before the beginning of the operating season.



We hope you enjoy many years of carefree warmth with this ARTE® ASSOS woodstove. Some initial experimentation with loading and operating techniques will help you decide your normal routine. If you have any problems after this short learning period, please contact your local ARTE® dealer. In case, for any reason, they can't help, please contact us in writing at the address on the front of this manual

10. TIPS & TRICKS FOR RESOLVING ISSUES

The wood does not ignite by lighting the fireplace. The fire just smokes. The fire burns out

- ① Open the air supply
- ① You are not using proper kindle
- ① The wood is too wet
- ① The logs are too thick
- ① The ash is over the appropriate limit

Intense smoking in the combustion chamber, intense soot deposition on the glass

- ① Open the air supply
- ① Small quantity of wood
- ① The wood is too wet
- ① The logs are too thick

There is smoke coming out of the fireplace

- ① Check if there is adequate draft into the flue, light a test fire
- ① Make sure there is sufficient air supply



The qualified dealer in your area is available to answer any of your further questions

11. DIMENSIONS

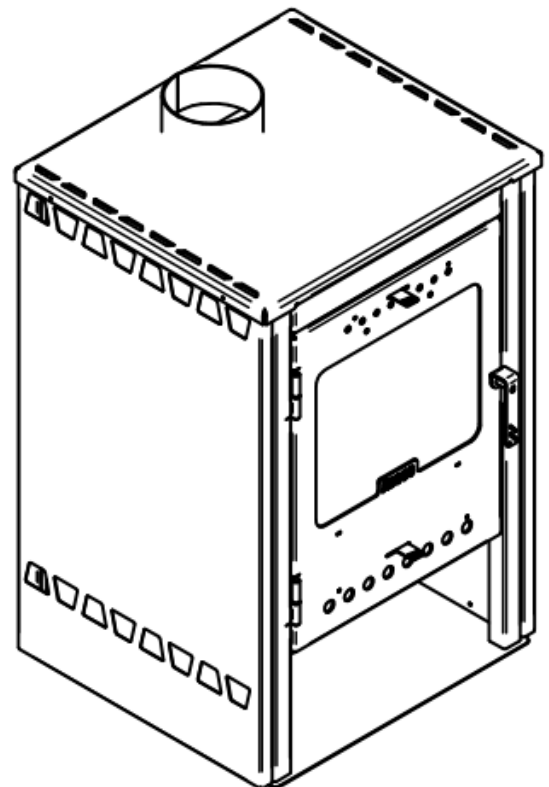
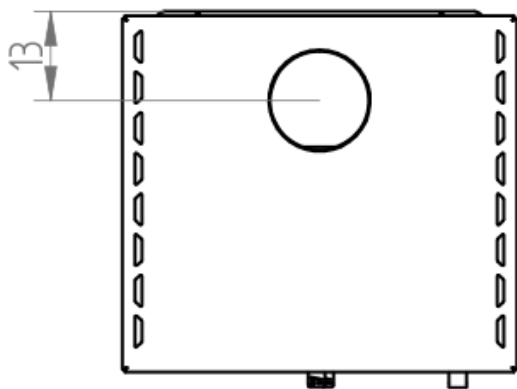
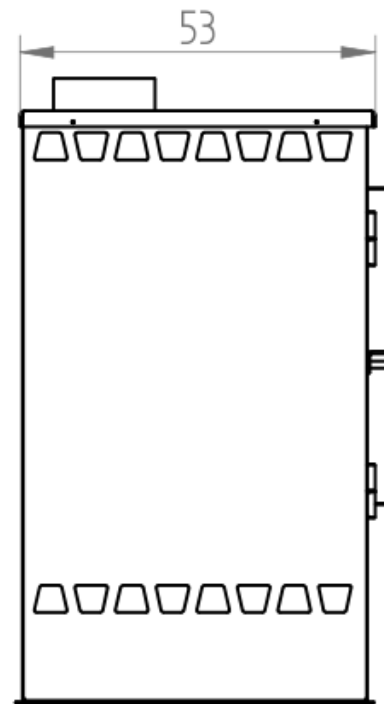
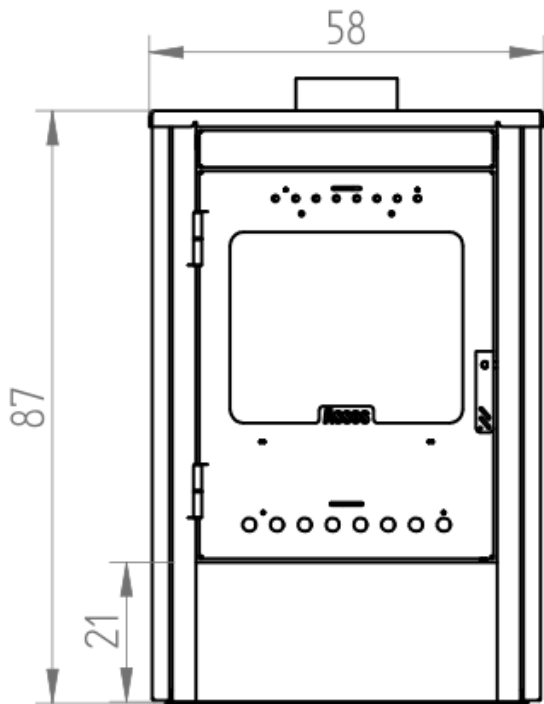

All dimensions are in centimeters (cm)

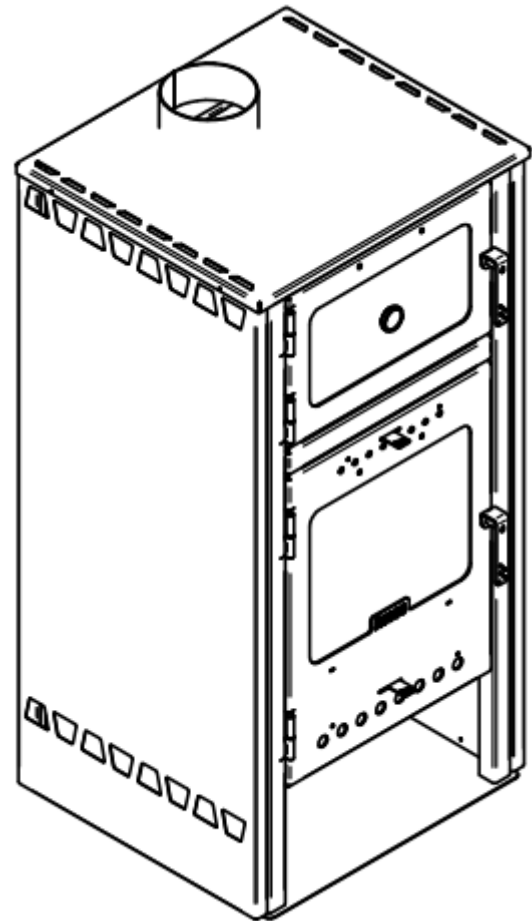
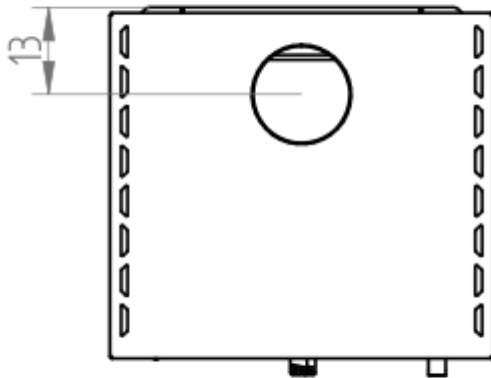
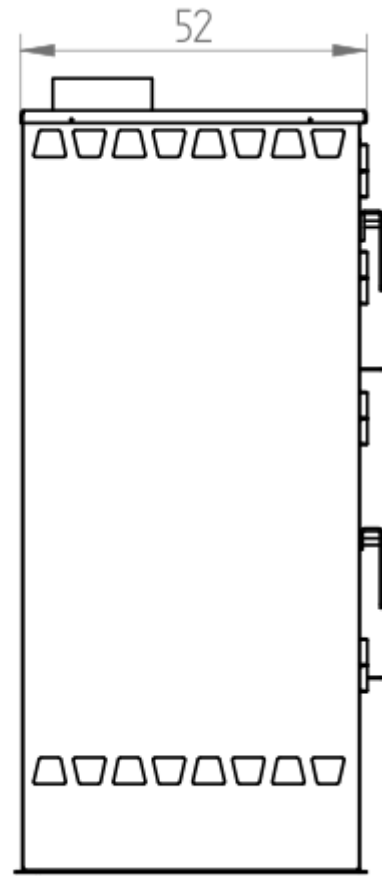
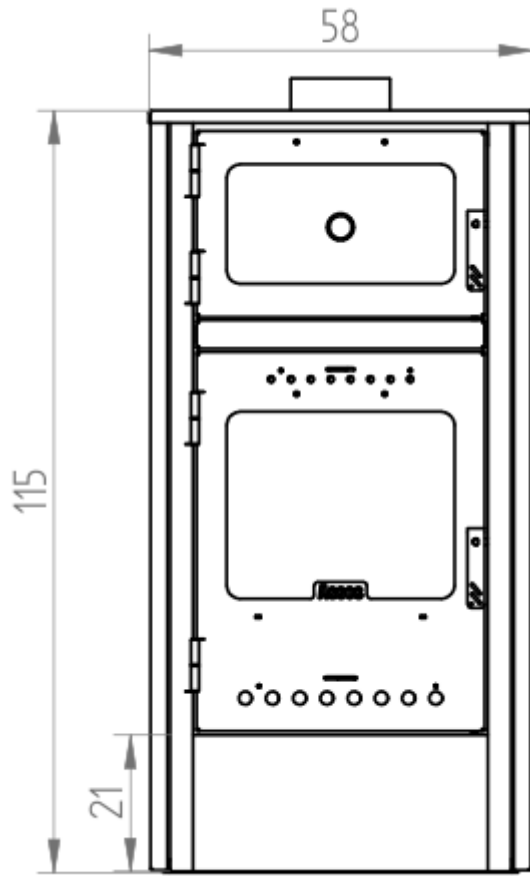

All dimensions are in centimeters (cm)

12. TECHNICAL SPECIFICATIONS

TECHNICAL SPECIFICATIONS	UNITS	ASSOS	ASSOS AIR
*Total heat output	Kcal/h	11619	12410
	kW	13.51	14.43
Recommended hourly consumption of firewood	Kg/h	4.33	4.52
Heat output	%	72.3	74.03
Exhausts temperature	°C	294	283
CO emissions (by providing O ₂ at 13%)	%	0.262	0.256
Yield range (minimum - maximum)	kW	7.0 - 18.7	7.2 - 18.8
Fuel	-	Wood, Briquette	
Device dimensions (W x D x H)	cm	58/53/87.5	58/53/115
Combustion chamber dimensions (W x D x H)	cm	43/43/38	
Oven dimensions (W x D x H)	cm lt	-	40.5/42/21 36
Flue draft	Pa	12	
Heated area	m ²	45 - 140	45 - 135
Weight	kg	100	125
Smoke outlet diameter	cm	Ø 15	
**Minimum flue height	m	4	
Minimum heating area	m ²	45	45
<p>* The woodstove operates with intermittent combustion technology. In this case intermittent combustion means the normal use of the fireplace, e.g. new firewood is added as soon as the previous are burned, forming a sufficient amount of cinder.</p> <p>** The internal section of the flue must be increased by 10% per 500m altitude above sea level.</p>			

Table12.1

13. WARRANTY

We grant a two year warranty for your new ARTE® ASSOS woodstove. The warranty period begins on the day the fireplace is installed and tested by a qualified dealer. We also grant a one year warranty for all the electrical parts (if any are installed).

Warranty claims become valid when the purchase price for the fireplace has been paid in accordance with the agreement and the warranty certificate has been completed and returned within thirty days to ARTE® G. Karnoutsos & CO.

If any of these conditions is not fulfilled the minimum warranty of six months applies.

13.1. Warranty terms

- ① Proper installation by a qualified dealer
- ① The fireplace is operated in accordance with these operating instructions
- ① No continuous firing
- ① No overheating
- ① Regular maintenance / cleaning (at least once a year)
- ① There must be no modifications to the fireplace structure: these can cause malfunctions and permanent damage

13.2. Excluded from the warranty

- ① Wearing parts like gaskets, vermiculite panels and glass
- ① Smoke and soot damage
- ① Natural discoloration or deviating colors on the outer cladding
- ① Cracks in the combustion chamber that have no effect on the safe functioning of the ARTE® ASSOS woodstove
- ① Damage incurred through failure to follow these operating instructions
- ① Damage covered by an insurance policy or other agreement

13.3. Responsibility

Upon delivery of this manual ARTE® declines all liabilities, both civil and penal, for any accidents that may derive from the total or partial failure to comply with the specifications contained in it.

ARTE® also declines all responsibility resulting from an improper use of the appliance, incorrect use by the user, from unauthorized alterations and/or repairs, or the use of non-original or non-specific spare parts for this particular fireplace.

13.4. Emergency maintenance

Emergency maintenance on the fireplace model to which this manual refers, must be carried out by qualified personnel.

13.5. Responsibility for installation

It is not the responsibility of ARTE® to carry out the work needed to install this fireplace. Such works are entirely up to the installer who is requested to check the flue and air intake and to check if the installation solutions proposed are feasible. All applicable standards and local, national and European legislation in force in the country where the fireplace is installed must be respected.

13.6. Usage

Use of the appliance is subject to compliance with all the safety standards established by the relevant laws in force in the place of installation, in addition to the instructions contained in this manual.

13.7. Legal guarantee

The user may only make use of the legal guarantee, as under the EEC directive 1999/44/CE, if he has scrupulously complied with the regulations indicated in this manual, and more specifically:

- ① To work always within the fireplace limits of use
- ① Maintenance must be constant and careful
- ① Only allow people who are capable and who have been suitably trained to use the fireplace

Failure to comply with the instructions provided in this manual will invalidate the guarantee immediately



In order for the warranty to be applicable, please fill out the form on this manual's last page

NOTES

S/N:



Εργοστάσιο - Έδρα
Προέκταση Μακρυγιάννη
Εύοσμος | Θεσσαλονίκη

Αλληλογραφία
Τ.Θ. 40 124, Τ.Κ. 564 10
Σταυρούπολη | Θεσσαλονίκη

τ. 2310 684 148
φ. 2310 684 149
e. info@arte-fireplace.com

Factory - Head Offices
Makrygianni Str.
Evosmos | Thessaloniki | Greece

Mail
P.O. Box 40 124, P.C. 564 10
Stavroupoli | Thessaloniki | Greece

τ. 2310 684 148
φ. 2310 684 149
e. info@arte-fireplace.com

www.arte-fireplace.com