



MENTOR LINE

ENERGY EFFICIENT FIREPLACE



**INSTALLATION
& USER MANUAL**



TABLE OF CONTENTS

1. Arte® Fireplace - A Greek Quality Product	1
2. Facts about the wood and the environment	1
2.1. Why should I use wood?	1
2.2. Buying firewood	1
2.3. Storing your wood	1
2.4. Wood types and calorific value	2
2.5. Determining the heat output	3
3. Endorsements and certifications	3
3.1. Endorsement	3
3.2. Features marking plate	3
4. Packaging	4
4.1. Unpacking the fireplace	4
5. Installation and fire safety	5
5.1. Height adjustment, leveling of the fireplace & door's counterweights adjustment	5
5.2. Safety distances	5
5.3. Wooden beams protection	5
5.4. General safety instructions	5
5.5. Flue safety instructions	6
- Basic requirements for proper flue operation	6
- Chimney placement	6
- Chimney cap	7
5.6. Connecting the fireplace with the flue	8
5.7. Air intake connection	8
5.8. Hot air abduction	9
5.9. Fireplace with galvanized covers and hot air system (Optional)	9
- Hot air outlet	9
- Connection of motor and thermostat	10
5.10. Installation examples with hot air supply to more than one room	12
6. Usage instructions	13
6.1. Before the first use of the ARTE® MENTOR fireplace	13
6.2. About the ARTE® MENTOR fireplace	13
6.3. General information	14
- When the fireplace paint dries	14
- Incineration preparation	14
- Combustion air intake	14
- Power failure (when there is a motor)	14
- Heating during seasonal change or in adverse weather conditions	14
- ADF function	14
6.4. Usage of the detachable handle ("Cold handle")	15
6.5. Adjustment of combustion air	16
6.6. Setting and function of the thermostat (Optional)	16
7. Lighting the fireplace	17
7.1. Traditional method of lighting	17
7.2. Lighting without CO emissions (FROM TOP TO BOTTOM)	18
7.3. Safe handlings in case of wrong functioning	18
7.4. Smoke escape in the room	18
8. Tertiary combustion	19
9. Cleaning and maintaining the fireplace	19
9.1. External maintenance	19
9.2. Internal maintenance	20
- Ash disposal	20
- Glass	20
- Gasket	21
- Internal parts that need maintenance	21
9.3. Cleaning the fireplace and the flue	22
- Chimney sweeping	22
- Annual maintenance	22
- How to clean the inside parts of ARTE® MENTOR	22
9.4. Internal parts	23
- Removal of the 1 st baffle	23
- Removal of the 2 nd baffle	23
- Removal of the 3 rd baffle	23
- Removal of side vermiculites	24
- Removal of back vermiculites	24
- Removal of the bottom vermiculites (Floor)	24
- Removal of the bottom vermiculites (Front side)	24
9.5. Inactive fireplace for prolonged periods	24
10. Tips and tricks for resolving issues	25
11. Dimensions and technical specifications	26
12. Notes	28

1. ARTE® FIREPLACE - A GREEK QUALITY PRODUCT

Thank you for buying an ARTE® fireplace - we believe that you will have as much pleasure from our product as we have, producing it.

Your ARTE® fireplace is made in such a way, to extract the maximum possible energy from the wood with the minimum possible emissions, using the most innovative technology and the most robust design – one product **made in Greece!**

These instructions contain interesting and informative facts and all you need to know about the subjects of heating, wood, and operating your ARTE® fireplace. Please read these instructions carefully before using your fireplace for the first time and keep them for future usage.



The manuals which are enclosed with the product must be kept throughout the product's entire service life. They are also available online in our website.

2. FACTS ABOUT THE WOOD AND THE ENVIRONMENT

2.1. Why should I use wood?

With proper forest management, burning wood does not deplete the earth's resources. Heating with wood usually does not contribute to global warming. The young trees that replace the trees that you burn in your fireplace absorb carbon dioxide (CO₂) from the air. Burning firewood releases only as much CO₂ as the tree has absorbed from the atmosphere during its growth. Similarly, wood rotting in the forest generates the same amount of CO₂ as the same wood burning.

Besides being environmentally friendly, the heat from a fireplace warms you like the warming rays of the sun during the sunny winter days. It is the radiated heat that is transmitted by electromagnetic waves in the infrared range. Even when the air is very cold you can feel the warm rays of the sun on your skin.

Another advantage of wood is that it is produced locally, which creates local employment, and more tax revenues stay in the province.

2.2. Buying firewood

Where can I get my firewood?

Regenerated ready-to-burn firewood can be purchased from dealers:

- ① Fireplace ready, stored for at least two years
- ① Pre-dried, stored for one year
- ① Fresh from the forest

Whether you have cut your own wood or bought it, the important thing is that: the wood should be dried for **at least two years before it is burned.**



The ideal residual moisture is 12 - 15% and should be no higher!

2.3. Storing your wood

The full potential for heat will not be realized if you neglect the simple but necessary chore of piling and protecting your wood. Proper storage is essential to avoid moisture, bacteria, and insect problems in your home.

To avoid problems with insects and moisture, store the wood as far from your house as is practical. Do not store wood in your basement; one cord of wood (4 m³) can give off more than 500 liters of water. The basic rule is to protect the wood from water, but not from the sun or wind

(**Pic. 2.3.1 & 2.3.2**) Green wood will dry slowly or not at all if unprotected, while seasoned wood left unprotected may become unseasoned.

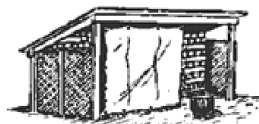

Pic. 2.3.1

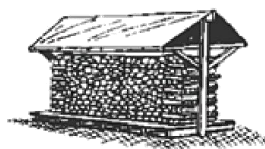

Pic. 2.3.2

There are three basic rules to follow when storing wood:

- ① Allow air circulation by piling the wood alternately (one layer across – one layer widthwise), if possible.
- ① Protect wood from rain and snow by covering it with a tarp or woodshed roof. Otherwise, place it under a shed with a wooden roof.
- ① Pile wood off the ground on scrap lumber or wooden pallets.

The time-honored way to cure wood is to buck, split, and stack wood off the ground for one full year. Although wood can generally be reduced to 20 per cent moisture content in two to three months, the ideal 10% to 15% may take longer (almost 18 months).

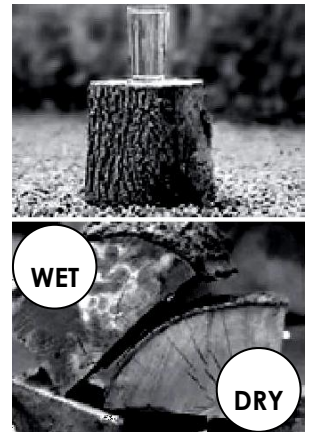

2.4. Wood types and calorific value

A wood's efficiency does not depend only on its type, but also on its humidity, as well as the temperature of the combustion chamber.

For more efficient and longer burning, without emission of hazardous substances, woods must be dry. Ideally, their humidity percentage must not exceed 10% to 15%.

If this percentage is over 20%, the wood is not burned properly, whereas if the piece of wood has been cut recently, the humidity is over 60% making it unsuitable for burning. The reason for that is that the fire will be weak and pale and will produce dense smoke, unburned tar and creosote, soiling the ceramic glass and the flue.

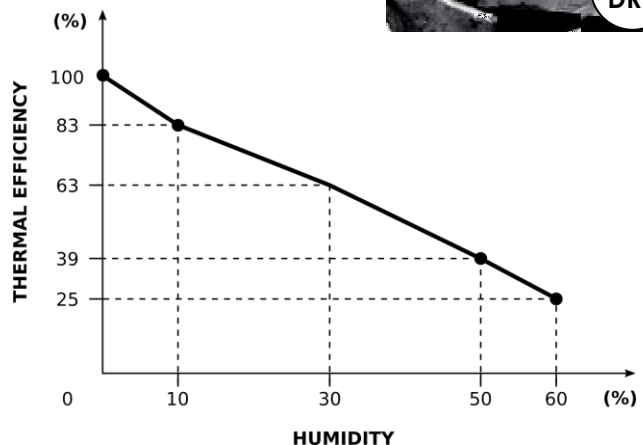

It is preferable to get your wood supplies during the summer months and store them, to ensure better combustion quality during the winter.

Useful tips

- ① Always choose dry firewood.
- ① Avoid wood that pops (chestnut, conifers such as cedar, spruce and pine), as they may damage your fireplace or the flue.
- ① Pay attention to the size of the logs. Good firewood must have been cut at least twice.
- ① You should prefer oak, beech, olive wood, which is hard wood with high density since they will burn for longer.

Briquettes

They ignite very easily, and burn slowly. They are economically advantageous because you will burn smaller quantities compared to common firewood and they are easily stored. Also, you have less quantity of ashes in comparison to wood.

Birch

It's a soft wood that ignites easily with great thermal energy production. It produces less smoke and ash compared to other wood and burns silently. The same characteristics apply for lime and chestnut.

Beech

Hard wood is ideal for firewood but requires a high temperature to ignite. It weights a lot; it is dense and burns with a calm and long fire for a longer time. Best when well seasoned. The same applies for oak, but seasoned for 2-3 years. Every type of wood has its own calorific value.

Wood type	Briquette	Birch	Walnut	Oak	Beech	Fir	Common Oak	Pine	Olive
Calorific value (Kcal/Kg)	5.000	4.800	4.731	4.619	4.578	4.588	4.548	4.457	4.100

860Kcal/h = 1 kW/h

Table 2.4.1

The values are based on 15% residual wood moisture.



An ARTE® fireplace can be fired with all of the above wood types.

2.5. Determining the heat output

There is not a specific rule that enables the calculation of the required heat output. This depends on the amount of space that is required to be heated and mostly on its insulation. In average the required heat output for a properly insulated room and with external temperature of 0 °C is 40 kCal/h per m³.

Taking into account that 1kW equals 860 kCal/h an equivalent of 50W/m³ can be used. For example, to heat a 150 m³ room (10 x 6 x 2.5m) in an insulated residence, the output required is 150m³ x 50W/m³ = 7500W or 7.5 kW.

So, for the main heating, a 10kW appliance is enough.

Fuel	Unit	Indicative combustion value with efficiency ~80%		Required amount relative to 1kg dry wood
		kCal	kW	
Firewood (moisture 15%)	kg	3600	4.2	1.00
Firewood (moisture 50%)	Kg	1850	2.2	1.95
Wood briquettes	Kg	4000	5.0	0.84
Coal briquettes	Kg	4800	5.6	0.75
Coal	Kg	7700	8.9	0.47
Coke	Kg	6780	7.9	0.53
Gas	m ³	7800	9.1	0.46
Diesel	L	8500	9.9	0.42
Electricity	kW/h	860	1.0	4.19

Table 2.5.1

3. ENDORSEMENTS AND CERTIFICATIONS

3.1. Endorsement

The ARTE® fireplace you chose has been tested according to **EN13229**. The declaration of performance (DoP) of each MENTOR model can be found at the URL of the company for each model.

3.2. Features marking plate

ARTE® fireplace's feature marking plate is located on the right side of the appliance.

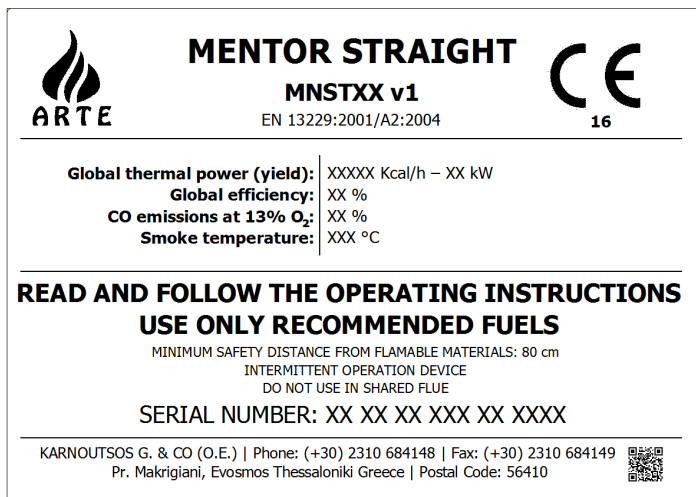

4. PACKAGING

ARTE® is devoted in protecting the environment, so we use as much recyclable materials as possible and the least amount of packaging materials without compromising the secure transfer of our products.

4.1. Unpacking the fireplace

1. Your product will be delivered on a wooden pallette which is lined with wooden side panels **(Pic. 4.1.1)**.
2. Firstly remove the side panels. **(Pic. 4.1.2)**
3. Because of sharp objects, carefully remove the plastic membrane and the waterproof plastic film and also all the polystyrene on the outside and inside of the product.
4. Unscrew the 4 screws located on the bottom side of the product, in order to release the fireplace from the pallette. **(Pic. 4.1.3)**

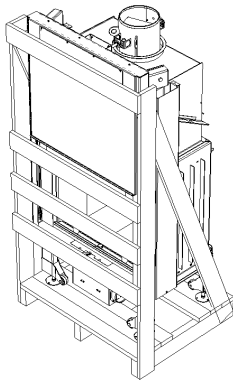

Pic. 4.1.1

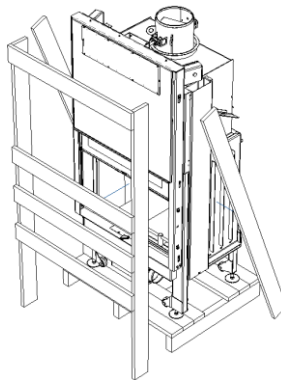

Pic. 4.1.2

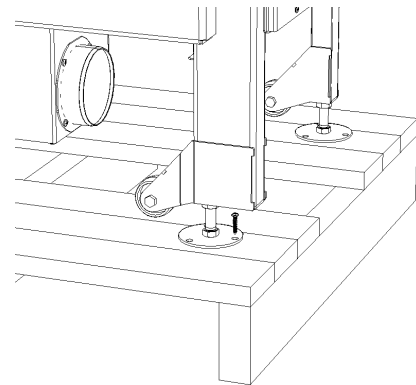

Pic. 4.1.3

5. Carefully lift up the product and place it on the installation point, making sure that the floor can withstand the weight of the device. Also, make sure you provide proper insulation in case the floor is built using flammable materials.
 - For the lifting, use 2 shackles and a belt **(Fig 4.1.4)**. (Not included inside the package). Information about the weight of the device can be found at **Table 11.2**. The products that you will use for the lifting must be able to lift up the device with safety.
 - If you bought the lifting system with the handles **(Fig 4.1.5)**, place them at the corresponding sockets and secure them with allen screws M6x10 (detail).
6. . For safety reasons during transportation, the door is secured at the upper open position. To release the door, remove the bottom, right and left hexagon screws, which fix the counterweights **(Pic. 4.1.6)**.

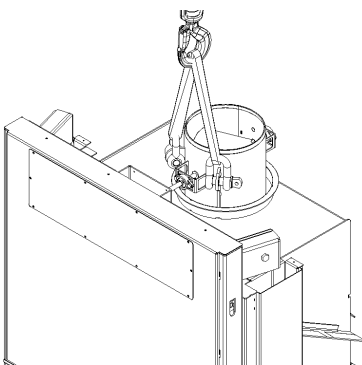

Pic. 4.1.4

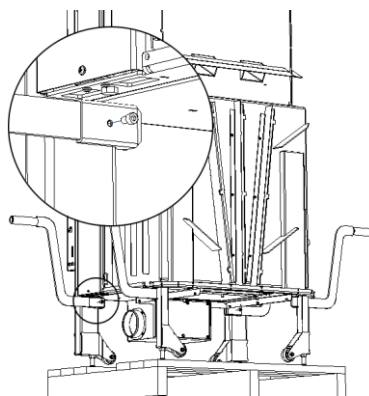

Pic. 4.1.5

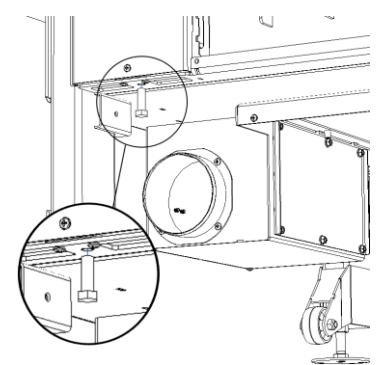

Pic. 4.1.6



The wheels which are fitted on the legs of the device, let you do small movements till the final installation place.

5. INSTALLATION AND FIRE SAFETY

During the installation of the fireplace, it is **OBLIGATORY** to respect the National and European rules and local regulations concerning building matter and fireproof rules.

The installation **MUST** be inspected by a qualified auditor, prior to lighting the fireplace. Also, the appropriate local authorities must be informed.

5.1. Height adjustment, leveling of the fireplace & door's counterweights adjustment

Adjust the legs of the fireplace at the desired height, taking into account that the device must be leveled. Leveling is important for the right function of the sliding door.

For the height adjustment, loosen the nuts which are located at the device's legs, and rotate the adjustment screws (**Pic. 5.1.1**). When you reach the desired height, tighten again the nuts. The distances that are shown in (**Fig 5.1.2**) must be kept.

For the adjustment of the door's counterweights, remove the right and left galvanized side covers. To remove them, unscrew the down screws and pull the cover upwards (**Pic. 5.1.3**). By adding or removing plates evenly at the both counterweights (right and left), you can affect the function of the door (**Pic. 5.1.4**). For safety reasons and well function of the fireplace, the door (during its assembly at the factory) is set to close at low speed.

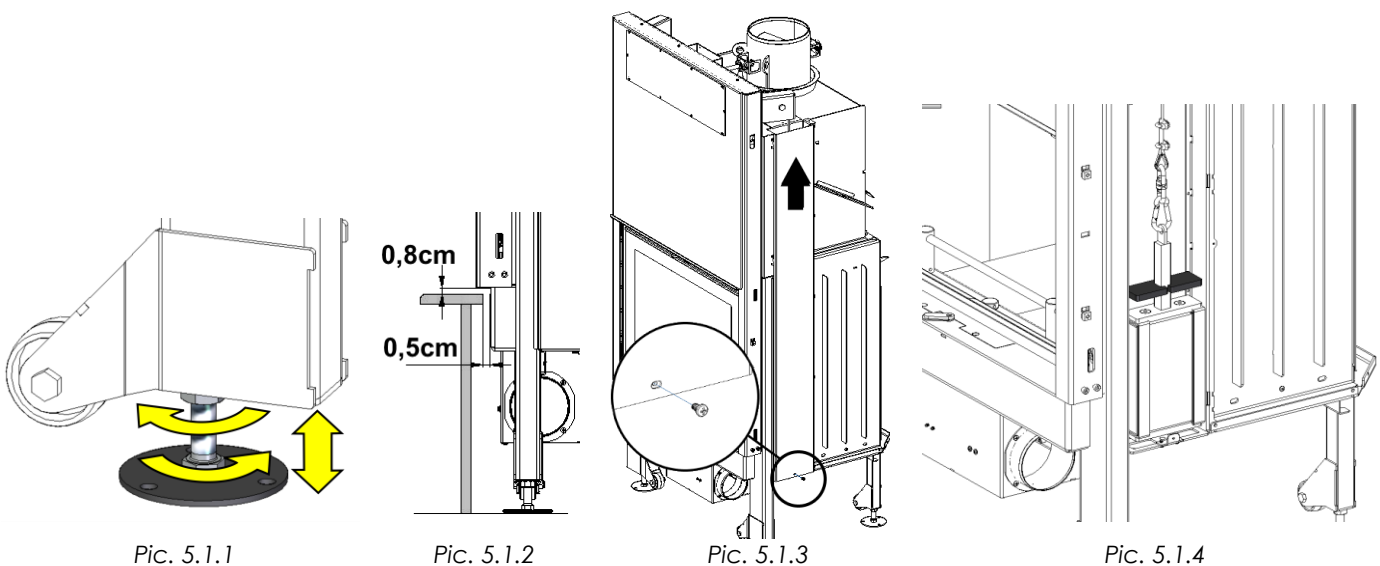

Pic. 5.1.1

Pic. 5.1.2

Pic. 5.1.3

Pic. 5.1.4

i In general, due to the expansion of the fireplace, the whole casing must have a gap, at least 0,5 cm, around the fireplace.

5.2. Safety distances

The combustion chamber opening must be **AT LEAST 80cm** away from any flammable materials that are inside the heat radiation zone (**Pic. 5.2.1**).

5.3. Wooden beams protection

Given its properties, heat is also transmitted through radiation. In case there are any wooden beams inside the radiation zone or in the way of the hot air, they **MUST** be properly insulated because the continuous exposure in high temperatures can make them deteriorate faster or even cause self ignition. Use proper insulation materials that are in accordance with European rules or, in case of high thermal stress you can also use metal linings.

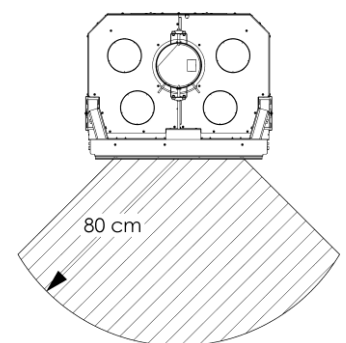

Pic. 5.2.1

5.4. General safety instructions

- Ⓛ Never leave children alone or without supervision near the fireplace when it is lit.
- Ⓛ Teach children how to operate the fireplace correctly and safely.
- Ⓛ Never touch the external surfaces of the fireplace or the glass when it is lit. There is a high risk of burns!

- ① Due to the self closing door, you have to be extra careful when you are filling the fireplace.
- ① It is forbidden to use the fireplace as a waste incinerator.
- ① Don't use burned or used wood as fuel.
- ① Remove the ash only after it has completely cooled off.
- ① Ash should be placed outdoors or be disposed in a place where there is no risk of ignition.
- ① Immediately inform your specialized local supplier if you find any malfunction.
- ① Don't use chemicals or liquids as fire starters.
- ① Do not use ANY fuel other than the recommended.



Follow the operating instructions supplied with the product to help prevent fire and protect the environment.

5.5. Flue safety instructions

Prior to installing the fireplace ARTE® the chimney sweep or a qualified technician should check the condition and operation of your chimney in accordance with the standards **EN13384-1** & **EN13384-2**.

By this way, you ensure the best conditions for heating without issues.

- Basic requirements for proper flue operation

- ① The internal section of the flue must preferably be circular. In a case of square or rectangular flue, the internal corners should have a radius of at least 20mm. In case of rectangular flue, the ratio of the sides should be at maximum 1: 1.5.
- ① The flue must be properly insulated and waterproof and constructed of materials with thermal resistance and resistance to combustion products and any deposits.
- ① The flue must have no constrictions, it must have a vertical path and it should not change in direction that exceeds 45° C (**Pic. 5.5.1**).
- ① In case of an existing flue the construction material should be checked. Materials such as cement with lime, galvanized steel and rough or porous materials are contraindicated as they create issues in the correct operation of the fireplace. Also, a proper study for the flue size must be conducted because often old flues have quite large diameters. This means that the amount of air draft is not proportional to the heat generated by the fireplace and by extension means that you consume more wood than necessary and will spend more time on maintenance. The solution proposed in these cases is the connection of an inner tube inside the flue. This tube should extend over the whole length of the flue and at no point should exceed in diameter the outlet flue of the fireplace. If the existing flue has the desired diameter a proper cleaning by qualified personnel should be done.
- ① In case of placement of the flue, along outer wall, a careful research must be done in order the thermal loses to be prevented. However, this solution is not appropriate as the placement of the flue inside the house, heats up more spaces, as the whole heat of the flue.
- ① The usage of gravitational damper is recommended, for flue $\geq 6m$, in order steady and efficient burning to be insured.

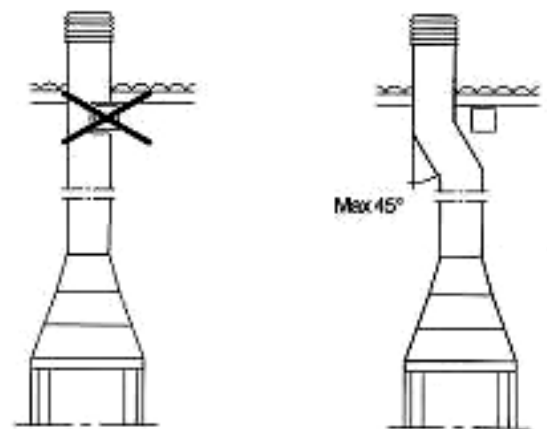

Pic. 5.5.1

- Chimney placement

The placement of the chimney on the roof is a particularly decisive factor in the convection of the fireplace.

An incorrectly fitted chimney may generate reimbursement of exhaust into the heating space due to down flow of the air.

Follow the instructions below to ensure proper dissipation of smoke (**Pic. 5.5.2**).

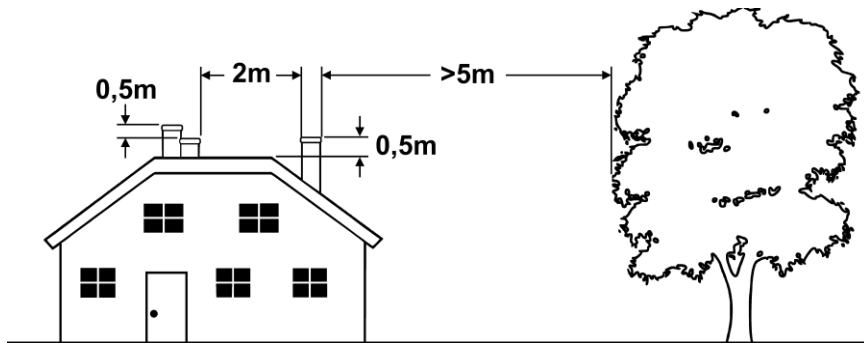

Pic. 5.5.2

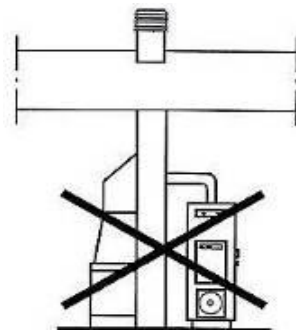

Pic. 5.5.3

- ① The ending of the chimney must be at least 50cm above the top of the roof.
- ① If there is more than one chimney on the roof, they must be positioned at least 2m apart.
- ① If there are two adjacent chimneys, their ends must be at least 50cm apart.
- ① If there is a tall building or tree next to the house, then you should place the chimney at a distance greater than 5m from the obstacle.
- ① It is prohibited to connect several devices to the same chimney. Each chimney should be autonomous (Pic. 5.5.3).
- ① In case of an inclined roof, the height of the chimney is defined depending on the inclination and the distance of the chimney from the ridge according to the following table and figure (Table 5.5.1 & Pic. 5.5.4).

INCLINATION α°	RIDGE – CHIMNEY DISTANCE	MIN HEIGHT ABOVE THE RIDGE
	A (m)	H (m)
15°	< 1,85 m	0,50 m OVER THE RIDGE
	> 1,85 m	1,00 m OVER THE ROOF
30°	< 1,50 m	0,50 m OVER THE RIDGE
	> 1,50 m	1,30 m OVER THE ROOF
45°	< 1,30 m	0,50 m OVER THE RIDGE
	> 1,30 m	2,00 m OVER THE ROOF
60°	< 1,20 m	0,50 m OVER THE RIDGE
	> 1,20 m	2,60 m OVER THE ROOF

Table 5.5.1

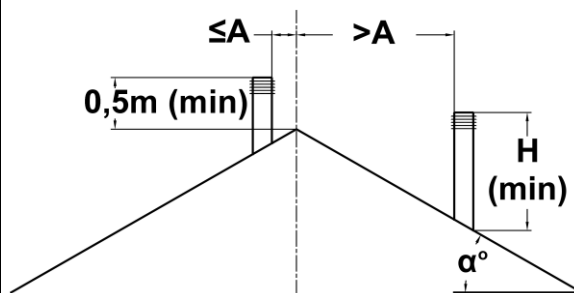

Pic. 5.5.4

- Chimney cap

The chimney draft depends broadly on the adequacy of the cap.

So, in case the chimney is built, its exhaust diameter should be at least twice the inside diameter of the chimney. Knowing that it is necessary to protrude from the ridge of the roof, the cap must ensure the proper smoke dissipation in case of strong wind.

A chimney cap must meet the following requirements:

- ① Internal diameter must be equal to the diameter of the chimney.
- ① Exhaust diameter be at least twice the inside diameter of the chimney.
- ① It should be constructed in such a way as to avoid the entrance of rain, snow and any foreign body in the chimney.
- ① It can be checked, maintained and cleaned easily.



Industrial style cap with protective net



Cap with fan. It provides very good smoke dissipation even in case of weak winds



Cap with deflector. It leans according to the wind and it provides very good smoke dissipation

5.6. Connecting the fireplace with the flue

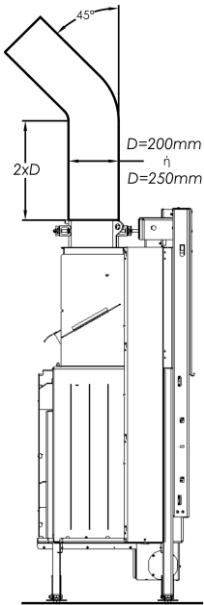

Pic. 5.6.1

It is necessary that the flue gas tube is connected to a certified conduit with the same diameter as the fireplace, by following the dimensions of the adjacent image (Pic. 5.6.1). For the fireplace MENTOR the diameter of the flue is 200mm for fireplaces with width 80cm and 90cm, and 250mm for fireplaces with width 100cm and 120cm. The flue must be properly insulated with stone wool with thickness of 4cm with external aluminum foil. **Do not use fiberglass or paper based insulation.** Also, do not use flexible thin walled metallic tubes or asbestos tubes. This tube should be perfectly sealed and well insulated throughout its length.

To install the flue, you must place it on the fireplace outlet and then seal it using the appropriate sealant.

5.7. Air intake connection

MENTOR fireplaces, gives you the ability to intake air for the burning from different sources:

A) The best solution is the air to be intake from the outer environment, opening a wicket directly on the wall, at the back side of the fireplace, adjusting a flexible aluminum tube on the $\Phi 100\text{mm}$ collar, which is located at the right edge of the fireplace and close to the bottom (Pic. 5.7.1). For the wicket, use a nozzle, protected by a grille and a wire net. The nozzle must intersect with the combustion chamber through the flexible tub, which must be properly placed in order not to be covered. Its minimum surface cannot be less than 110 cm^2 (A).



When the air comes from an external source, there must be always used the appropriate clamps and collar $\Phi 100\text{mm}$.

B) When the direct import of external air is impossible, you can input internal air from your house, by opening a wicket either at the area where the fireplace is located (Pic. 5.7.2) or from another adjacent room, by installing wickets at the intermediate walls (Pic. 5.7.3).

These wickets must be free and not able to be covered. Also, their minimum surface must be 300cm^2 (B), for example, a grille which size is $30 \times 10\text{cm}$.

In each case, you can select from which side of the fireplace you will import air, by changing the collar's position with the galvanized end cap that is located at the left side.

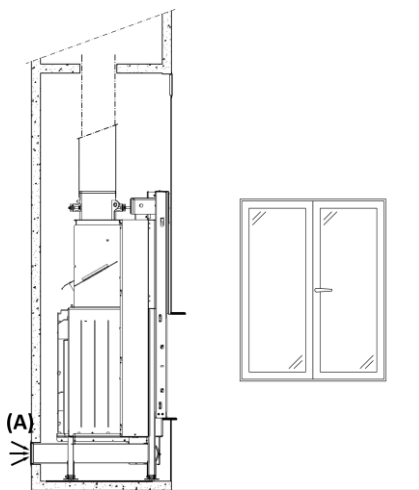

Pic. 5.7.1

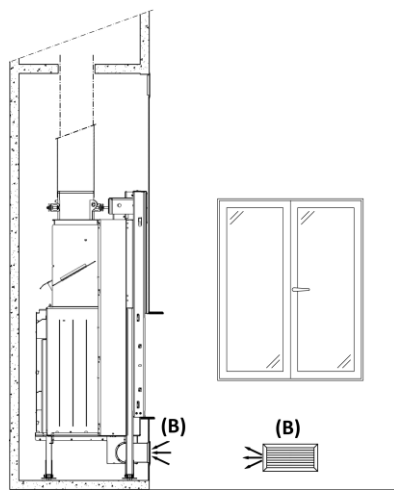

Pic. 5.7.2

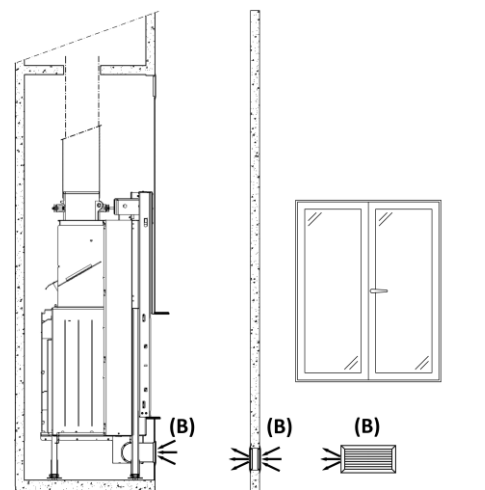

Pic. 5.7.3



The import of the air which comes from garages, kitchen, bathroom or boiler room, must be avoided.

5.8. Hot air abduction

The space extending around and over the device up to the deflector must be ventilated continuously. For this reason you must allow cool air from a lower spot, for example, the bottom and the outlet of the hot air from above (Pic. 5.8.1).

With that way, it can be achieved:

- ① Higher safety
- ① Increase of the temperature inside the heating room, because of the air flow around the device (heat conduction).

The hot air extract grille must be placed on top of the trunk approximately 20cm from the ceiling. The grille must always be installed, as its purpose is to allow, the heat that builds up inside the trunk to be released in the room and also to relieve the pressure created.

Finally, at the paneling of the fireplace, a visiting slot should be constructed in order for the installer or the user to have access to the internal parts of the door and be able to perform maintenance. For the determination of the L and H dimensions, you should consult the drawing at Chapter 11. Dimensions & technical specifications.

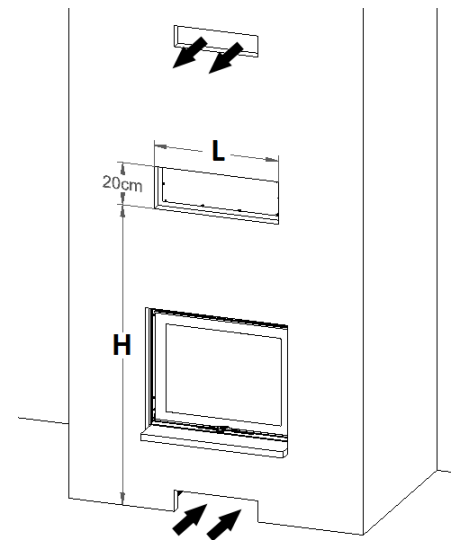

Pic. 5.8.1

5.9. Fireplace with galvanized covers and hot air system (Optional)

- Hot air outlet

At the top of the device, there are four closed and pre- shaped openings as exits of the hot air to the $\Phi 150\text{mm}$ tubes (Pic. 5.9.1). At least two of them must open. The outlets (1 & 2) are the most efficient for heating.

For the outlets (1 to 4): Open the pre-shaped openings with a hammer and connect the exit nozzles (like Pic. 5.9.2), connect the hot air tubes and tighten them with clamps. Also, they must be insulated with stone wool. Finally, cover all the exits at the paneling with adjustable grilles.

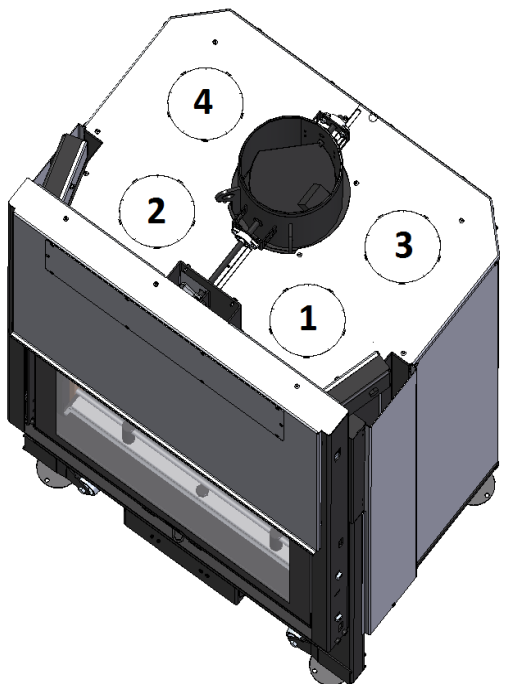

Pic. 5.9.1

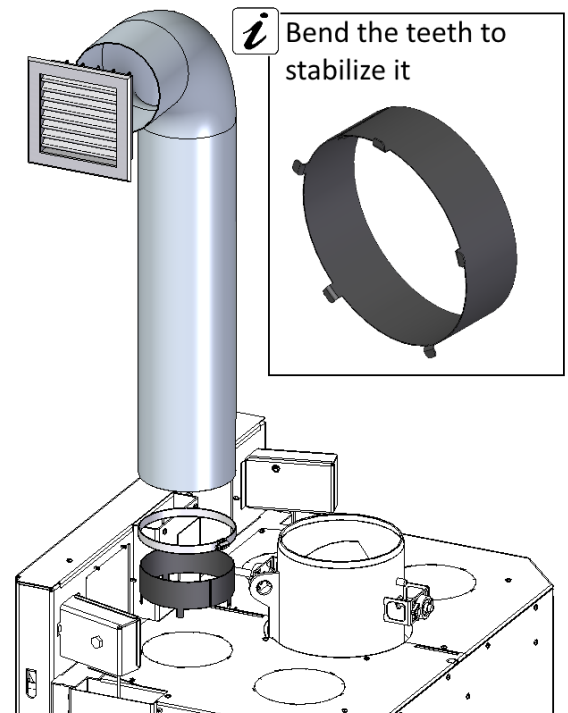

Pic. 5.9.2

- Connection of motor and thermostat

There are 2 pre-shaped air intakes for the motor, at the bottom left and right of the fireplace.

Open the pre-shaped openings with a hammer, place the Ø150mm tubes at the edges of the motor (right, left) and tighten them with clamps (Pic. 5.9.3).



Do not let the motor without the tubes, because there is danger that the smoke from the combustion chamber will enter into the heating air.

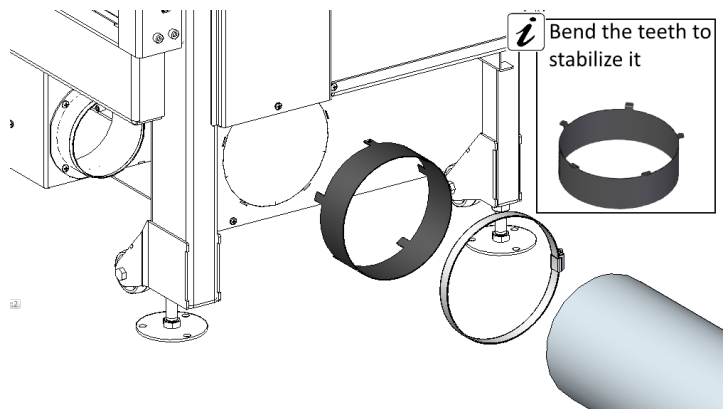

Pic. 5.9.3

Connect the other edge of each tube with openings at the areas from which you want to pump air for the motor (Pic. 5.9.4). If the intake for the combustion air is close to the air inlet of the motor, then there must be a minimum distance of 50cm between them.

Use adjustable grilles in order to close the tubes' openings and be sure that they must be installed at places where they will not be covered. Additionally, if they are located at an outer area, wire net must be used, in order insects not to enter.

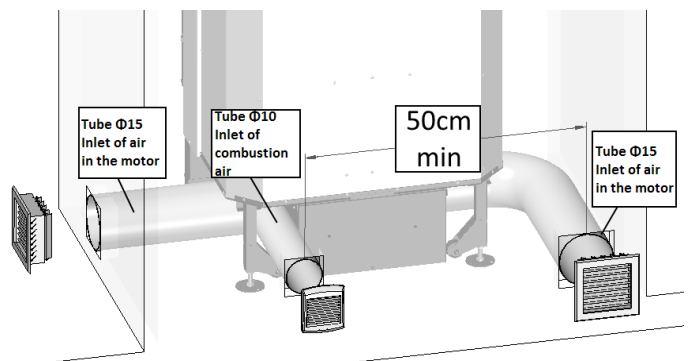

Pic. 5.9.4



For the motors' intake, you can use either external or internal air.
For installations at places smaller than 70m², it is recommended one tube to pump external and one internal air.
For installations at places bigger than 70m², it is recommended both tubes to pump internal air.

For the placement of the sensor and the control panel, follow the following instructions:

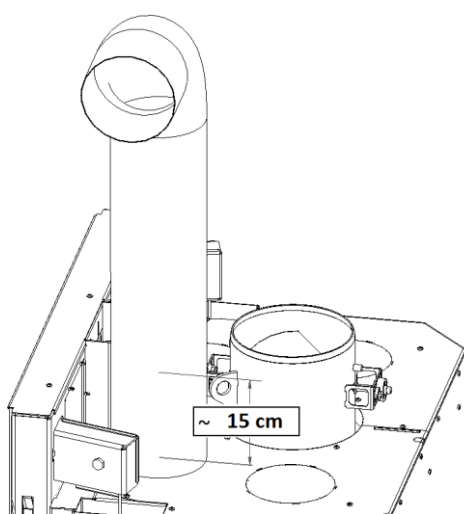

Pic. 5.9.5: The sensor of the thermostat must be placed at the air duct, approximately 15cm above of the cover of the fireplace.

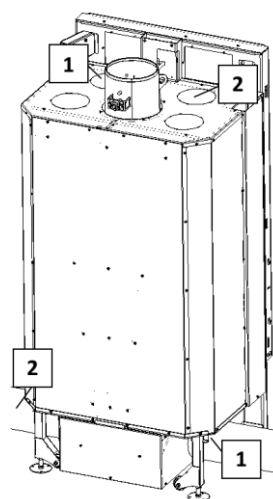

Pic. 5.9.6: Depending on the side from which the motor is supplied with external air, the thermostat must be installed at the antidiometric air duct.

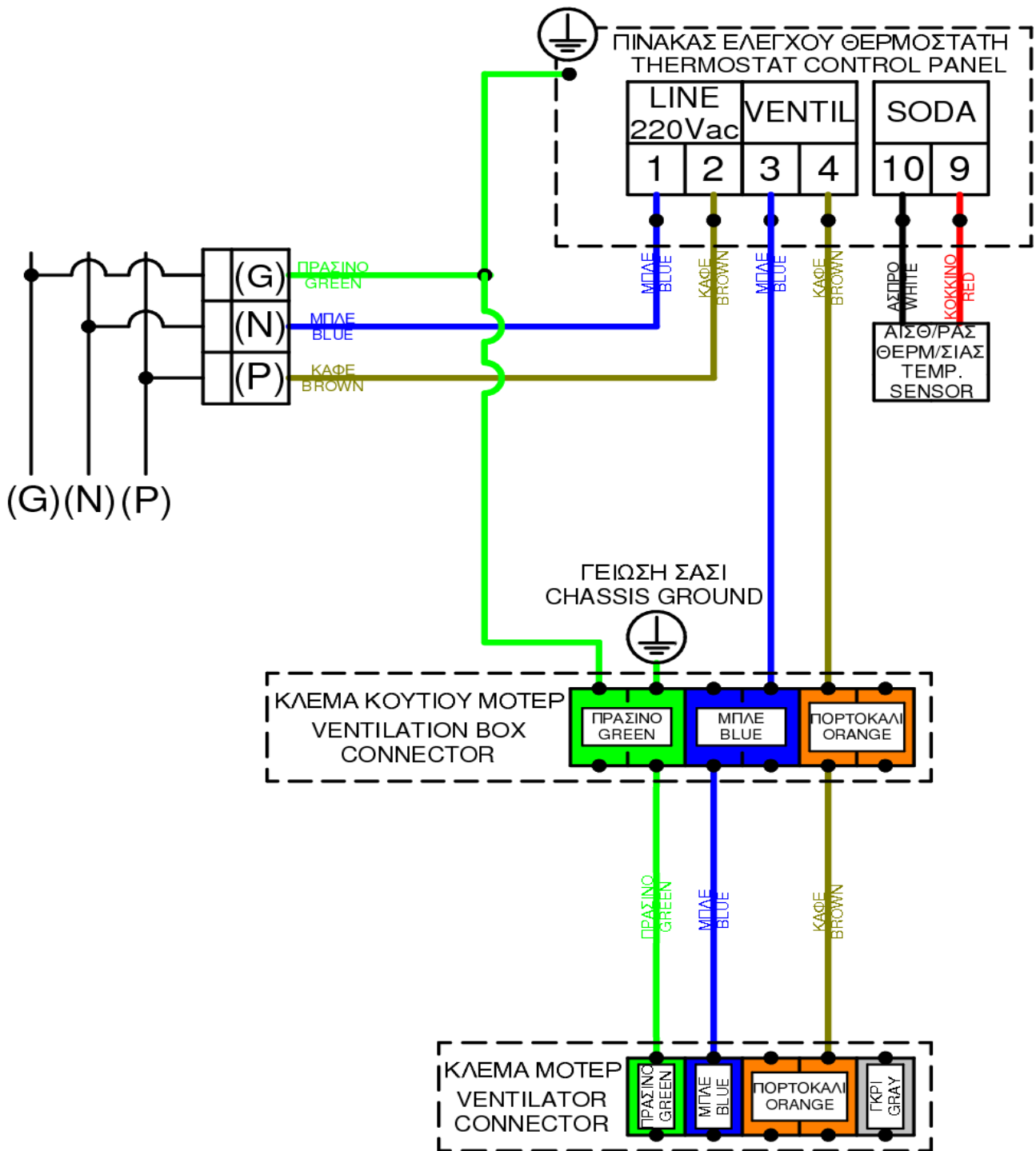

Pic. 5.9.7: Connect and install the electronic control panel with the motor, according to the graph.



The electric installation must be done EXCLUSIVELY only by specialized staff.

Place the panel of the thermostat at a cold place in order overheating of electric parts to be avoided.

5.10. Installation examples with hot air supply to more than one room

A) The following graph (**Pic. 5.10.1**) describes the main tube (distributor) of hot air which heats up more than one room. The max length of the distributor is 12m when the two front tubes of the fireplace are connected with a mixer/junction (made of galvanized and smooth sheet). Also, use smooth metallic tube for the 12m of the main tube (**Pic. 5.10.1**). The tube from the fireplace to the mixer/junction can be made by flexible aluminum tube (max 3m per tube).

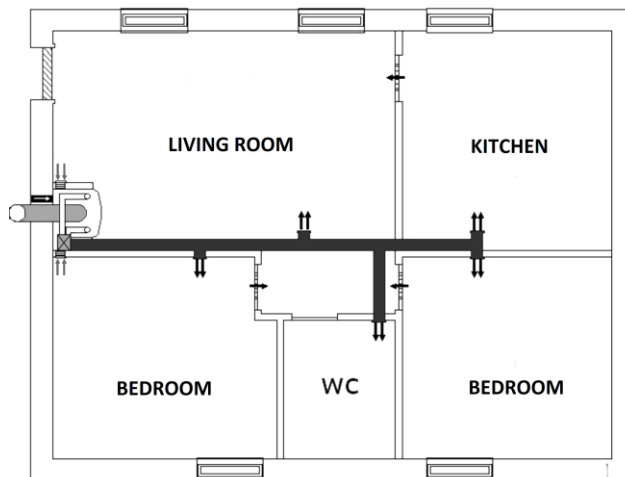

Pic. 5.10.1

B) Otherwise, 6+6m in a configuration of 2 tubes (**Pic. 5.10.2**) for different paths.

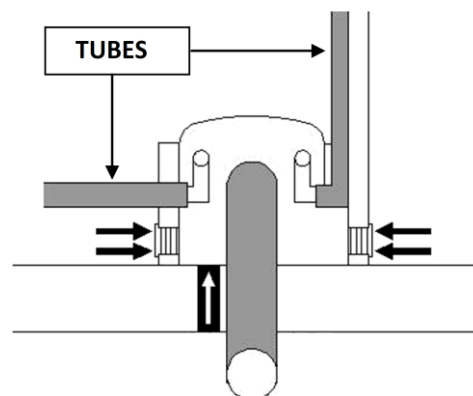

Pic. 5.10.2

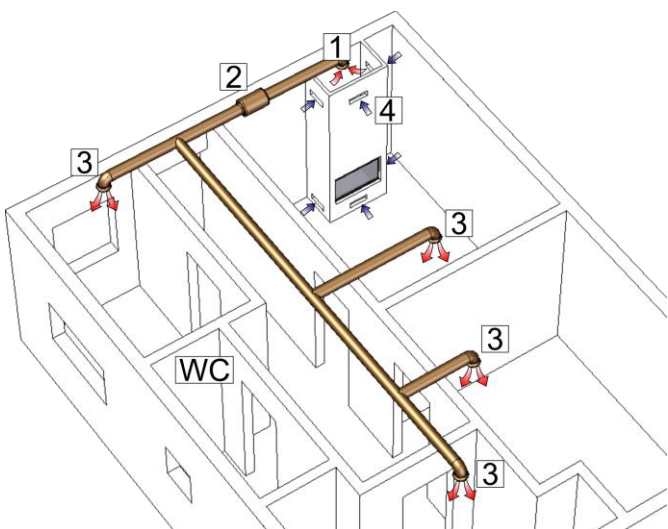

Pic. 5.10.3

C) When the galvanized cover and the hot air system (motor) do not exist, then another way to distribute air in more rooms, can be seen in (**Pic. 5.10.3**). From the **point 1**, the hot air is sucked by the linear ventilator (**point 2**). Through an air vent system, the hot air finally ends up at the rooms that we want to heat up (**points 3**).

In that case, it is necessary to open holes (at least one) (**point 4**) at the glazing of the fireplace that you will construct, in order decompression to be avoided. These openings must be free and not able to be covered. Also their minimum surface must be 300cm², for example a grille which size is 30x10cm.

In general, all the tubes and the mixers/junctions must be covered with glass wool (at least 3cm). Also, for the proper circulation of the air, there must be free flow of the air through these rooms, in order all the rooms to have the same temperature.

6. USAGE INSTRUCTIONS

6.1. Before the first use of the ARTE® MENTOR fireplace

One of our specialized representatives has already given you instructions about how to start the ARTE® MENTOR fireplace that you just bought.

At the following usage instructions, all the necessary steps that you must follow are analyzed in detail, in order not to face any problem during the function of your fireplace.

The specialized representative of your area is always available to answer any of your questions. The MENTOR fireplace is equipped with the following control systems:

6.2. About the ARTE® MENTOR fireplace

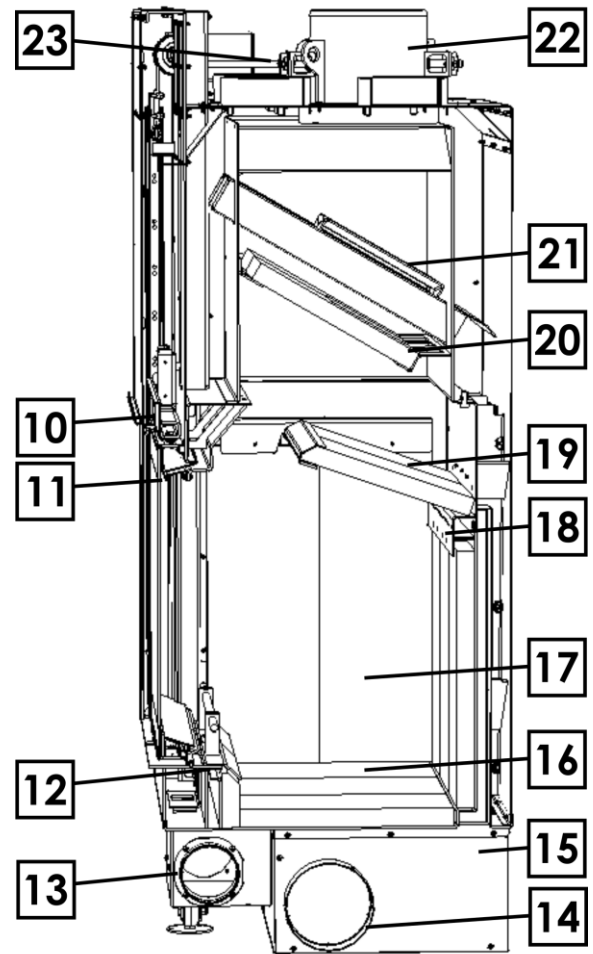
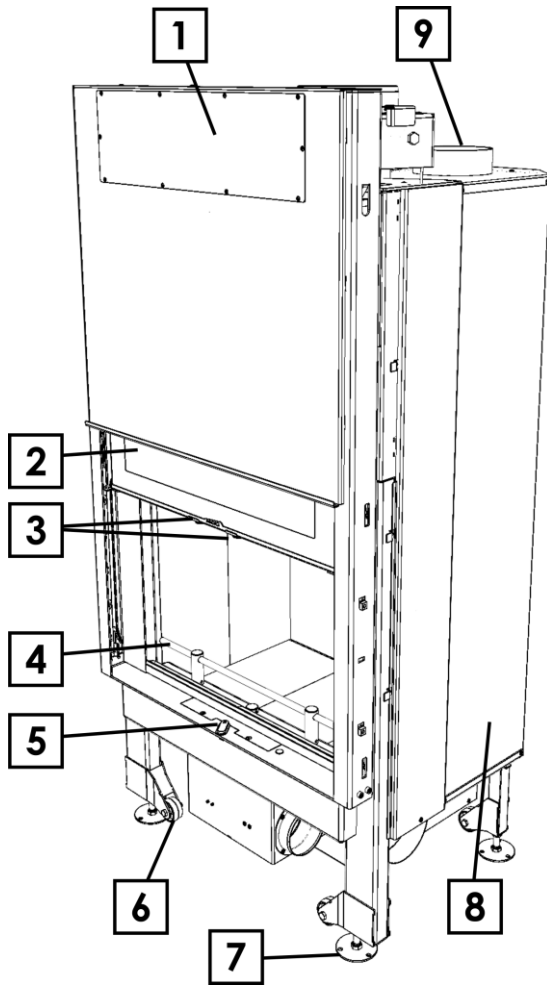

1	Check-maintenance port	13	Intake of combustion air
2	Main door with ceramic crystal	14	Intake for hot air ventilator (optional)
3	Attach point for cold handle (left & right)	15	Ventilator box for hot air (optional)
4	Log rolling guard	15	Bottom vermiculite, 1200kg/m ³ (or cast iron)
5	Combustion air adjustment regulator	17	Vermiculite panels, 750kg/m ³ (or cast iron)
6	Positioning wheels (during installation)	18	Secondary combustion air holes
7	Leveling and height adjustment feet	19	1 st baffle (vermiculite 750kg/m ³)
8	Galvanized cover (optional)	20	2 nd baffle (vermiculite 750kg/m ³)
9	4 air outtakes for adjacent rooms (optional)	21	3 rd baffle (metallic)
10	Adjustment regulator of automatic fume damper (ADF)	22	Flue
11	Upper air curtain	23	Automatic fume damper (ADF)
12	Primary air outlet		

Table 6.2.1

6.3. General information

- When the fireplace paint dries

ARTE® products are painted in spray booth with as more environmentally friendly and ecological colors as possible. There is although a possibility that the first few times the fireplace is lighted, the paint emits an odor. Let the fire burn with intense convection until all traces of gas disappear and there is no longer a smell. The gas is not toxic, but the room should be well ventilated.

- Incineration preparation

Prepare sufficient amount of chopped firewood, kindling and torches or branches. Before using the wood, it is recommended to store them in a warm place for a few days.

- Combustion air intake

Although the fireplace uses external air for combustion, make sure that the room is ventilated adequately when the fireplace operates with fresh air. When you open the door of the combustion chamber for adding firewood there should be no pressure difference between outdoor and indoor air in the room, so it is good to keep the door open for about 1.5cm for 5-6 seconds and then fully open it.



The air intake must be positioned so as not to allow being covered.

- Power failure (when there is a motor)

In case of power failure, you can still start or operate you ARTE® MENTOR fireplace normally. The only difference is that because the motor will not function, it will not give directly the heat inside the room but with heat convection. That is why we suggest you to use an UPS device with minimum power 1000VA (pure sine wave UPS), which will ensure you, nonstop function of your fireplace for approximately an hour.



During a power failure, the hot air distribution motor stops. But the ARTE® MENTOR fireplace is safe.

- Heating during seasonal change or in adverse weather conditions

When there is high humidity or fog, with temperatures ≥ 15 °C, but also during the transitional period between seasons, it is recommended to light a test fire before normally lighting the fireplace. This will displace the cold, heavy air that is inside the flue and create the right conditions for optimum smoke dissipation.

- ADF function

The automatic (and adjustable) fume damper [ADF] (Table 6.2.1, Line 10) enables you to adjust the damper to remain open in any position desired, even with the main door closed, in order to ensure adequate convection, depending on the height of the flue and the season.

e.g. Winter → Towards closed

Spring – Autumn → Towards open

To adjust the damper, turn the regulator right to close the damper and left to open it, checking the indicator in order to calculate its inclination (Pic. 6.3.1).

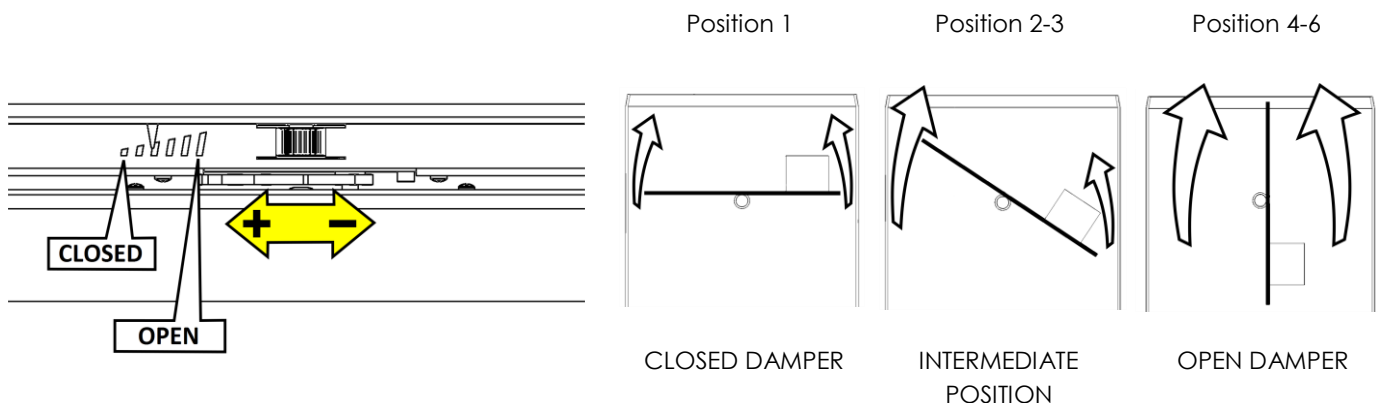

Pic. 6.3.1

6.4. Usage of the detachable handle (“Cold handle”)

The cold handle is a tool that you can use in order to open the door, even if the surfaces of the fireplace are extremely hot (**Pic. 6.4.1**).

The cold handle is provided in the standard edition combined with a magnetic base in order to place it on the wall (**Pic. 6.4.2**).

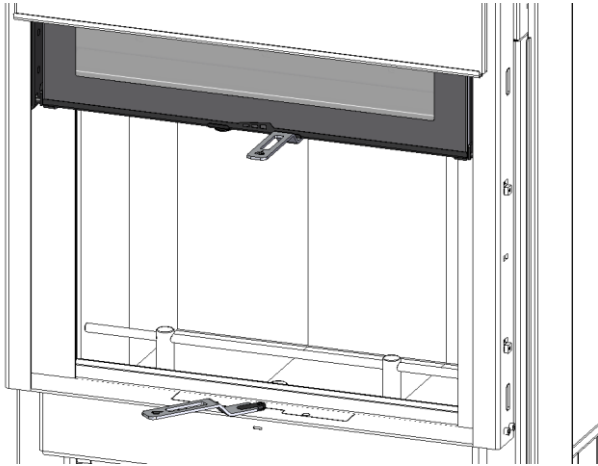

Pic. 6.4.1



Pic. 6.4.2

If you prefer the usage of a handle of your own choice or the ARTE's one, you can order special tools from ARTE in order to adjust them. The handle that you will choose from the market must be able to withstand high temperatures and agrees with the dimensions of **Pic. 6.4.3**.

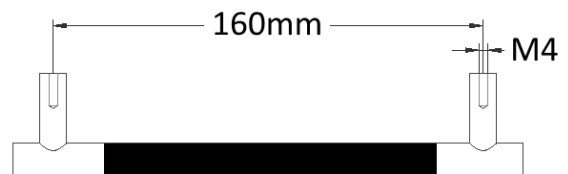

Pic. 6.4.3

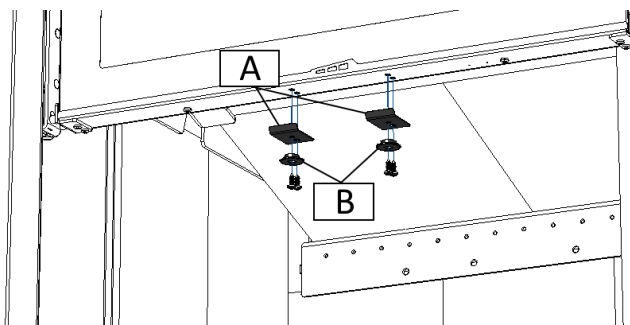

Pic. 6.4.4: In order to install the handle of your own choice, unscrew the 4 screws at the bottom and remove the A & B parts.

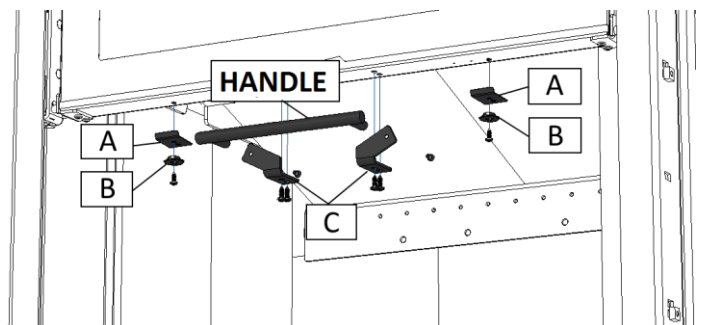

Pic. 6.4.5: Screw the handle with the C brackets with 2 flat head screws and screw everything at the bottom of the door, by screwing the screws that were removed before. Additionally place the parts A and B at the collateral positions (for the usage of the cold handle).

6.5. Adjustment of combustion air

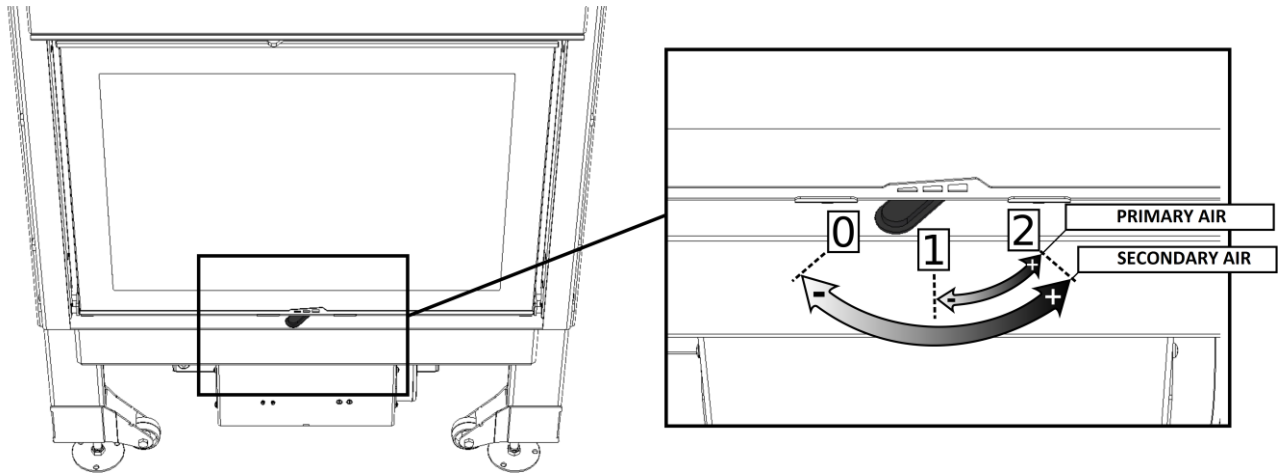

Pic. 6.5.1

The regulator adjusts the outer air that comes into the combustion chamber as follows: **(Pic. 6.5.1).**

- At the position 0, the primary and the secondary air are closed.
- At the position 1, the primary air is closed and the secondary is at 50%.
- At the position 2, the primary and the secondary air are 100% open.

Move the regulator in any intermediate position, between closed and open. In that way, you can control the combustion rate, either like you want or in relation to the wood quantity or the atmospheric conditions.

6.6. Setting and function of the thermostat (Optional)

Turn on the function ON/OFF of the control device by pressing the button A. The state ON/OFF is indicated by the L1 lightbulb.

➤ **How to OPERATE the control device**

1. **MANUAL** (indication MAN – lightbulb L2)

The fan operates in the selected speed, independently of the temperature of the sensor.
2. **AUTOMATIC** (indication AUTO – lightbulb L3)

The fan operates in the selected speed when the temperature of the sensor is higher than the one that is set on the thermostat (45°C).
3. **PROPORTIONAL** (indication PROP – lightbulb L4)

The fan increases its speed automatically, depending on the temperature of the sensor (from 45°C and above). If you forget to turn on the thermostat (it remains at the OFF position) before you light the fireplace and the temperature of the sensor reaches 100°C, then the device turns on (ON) automatically and starts to operate in MANUAL function, but after 10 seconds it passes to the PROPORTIONAL function, till the temperature drops to 90°C, so it goes back to the MANUAL function. This procedure will keep going till you select another function.
4. **ALARM** function

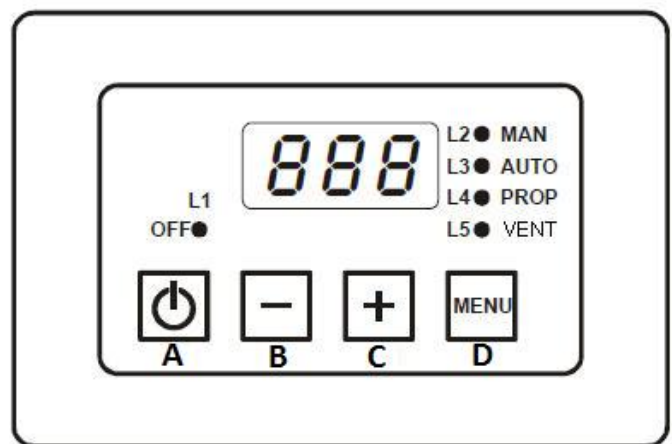

Pic. 6.6.1

If the temperature of the sensor rises above 130°C, an alarm is activated. By pushing any button, you can deactivate this alarm for 5 minutes. If after 5 minutes, and if the problem is not solved, the alarm is activated again.

➤ Main MENU

1. Selection of the function

Push the D button in order to see the selected function, which is written on the screen and the corresponding lightbulb lights up. By pressing again the D button, you can select one of the three function that are shown on the screen and mentioned by the corresponding lightbulb. The setting is saved automatically after 4 seconds. The lightbulb L5 shows the state of the fan.

2. Selection of the function's speed

By pushing the B and c buttons, you can see or change the current speed of the fan.

① P0 = OFF (only for MANUAL function)

① P1 = Minimum speed

① P10 = Maximum speed

This function is not available when the PROPORTIONAL function is selected.

For the AUTOMATIC function, you can select the speeds P1 ~ P10.

➤ ALARM OR MALFUNCTION SIGNALS

The control panel can indicate any malfunction of the sensor. Under these circumstances, the following lightsource indications may appear:

① LO: indicates low temperature (temperature lower than 0°C) | Open or not connected sensor

① HI: indicates high temperature (temperature above 180°C) | Shortcircuit of the sensor

7. LIGHTING THE FIREPLACE

Every time you light the fireplace, it initially requires large volumes of air. When the fireplace is cold, turn the regulator (**Fig 6.5.1**) at the maximum open setting (position 2).

To form an adequate layer of ash at the base of the fireplace, use 1-2 kg of dry kindling the first time you light it. If it is possible, constantly maintain a layer of ash with thickness of 2-3 cm at the base of the combustion chamber for added insulation.

7.1. Traditional method of lighting

- Place 2-4 kindling tablets or 7-10 wrapped newspaper sheets beneath 1-2 kg dry kindling.
- Turn the regulator (**Pic. 6.5.1**) at the maximum open setting (position 2).
- After 15-20 minutes a thick layer of cinder will be formed in the combustion chamber and the temperature will rise, which is essential for the continuation of combustion.
- Once the requirement described in **point 3** is met, place more logs on the cinder, with a distance of about 1 cm from one another.
- Turn the regulator (**Fig 6.5.1**) at the desired setting and close the door. The wood will begin to burn within 2-3 minutes. If not, turn the regulator at the previous maximum open setting.
- Ensure there is adequate air supply (oxygen) to maintain the flame clear and powerful when you adjust the regulator.
- As soon as the fire leaves a thick layer of cinder, you can add more firewood by repeating steps 4-6.

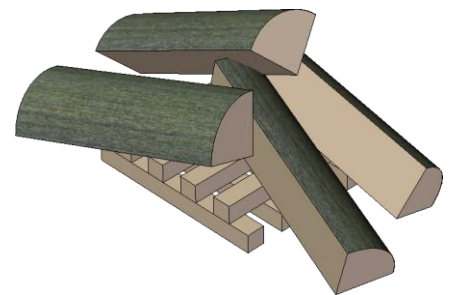

Pic. 7.1.1: Traditional method of lighting



To avoid covering the glass with soot, it is important not to let logs lean against it.

7.2. Lighting without CO emissions (FROM TOP TO BOTTOM)

1. Turn the regulator (**Fig 6.5.1**) at the maximum open setting (position 2).
2. Place logs, whose weight depends on the size of the fireplace, alternately (once lengthwise – once widthwise).
3. Add some torch (1-2 kg) in a length/widthwise together with 2-3 kindling tablets or 3-4 wrapped newspaper sheets and light them.
4. Once you ensure that the flue is warm enough (after 5-10 minutes) turn the regulator (**Fig 6.5.1**) at the desired setting, so that the combustion keeps going seamlessly and ensure there is adequate air supply (oxygen) to maintain the flame clear and powerful.
5. As soon as the fire leaves a thick layer of cinder, you can add more firewood.

Feed the fireplace often but with small amounts of firewood, always depending on the size of the fireplace. If the fireplace is overly full, the generated heat may cause excessive strain on the flue. The supply of firewood should be done in moderation.

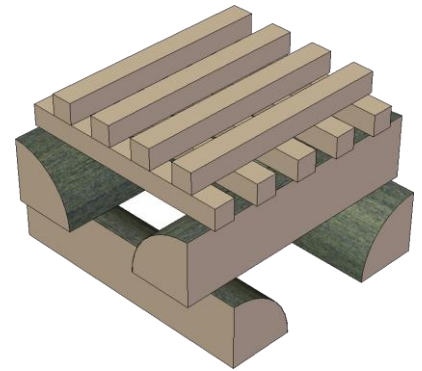

Pic. 7.2.1: Lighting without CO emissions



The openings of the air supply should not be covered by firewood.

The fire should be vigorous and the smoke exiting from the flue must be almost unnoticeable. The fire should not be smoldering because it is causing more pollution.

It is recommended installing a smoke detector in the room where the fireplace is located.

DO NOT OVERHEAT THE FIREPLACE AND DO NOT LEAVE THE DOOR OPEN! There is risk of fire or permanent damage. If any part of the fireplace starts glowing, then the device is overheating.

Wood combustion rules

- ① If you want less heat, put a smaller quantity of wood in the fireplace and reduce the amount of air. It is however important to maintain an adequate layer of cinder.
- ① Less heat = Less wood = Less air.
- ① More heat = More wood = More air.
- ① When the fireplace operates at excessively low power or if the wood is not sufficiently dry, soot might deposit on the glass.

7.3. Safe handlings in case of wrong functioning

In rare cases, even a test fire can cause not effective draft in the flue. In this case, call your chimney sweep.

In no case, you must not try to light a bigger fire. If smoke escapes from the fireplace, ventilate the room immediately and call your chimney sweep. **DON'T LIGHT THE FIREPLACE!**

7.4. Smoke escape in the room

Check the following:

- If for any reason you have left the door open during operation.
- If the flue is absolutely airtight.
- If the internal of the chimney is absolutely airtight from the top to the bottom – (Even a small crack or gap can spoil the insulation)
- If the throttle of the A.D.F. system is blocked or if cinders have stuck inside the pipe on the throttle.
- If the chimney is suitable and clean – (In each case, they must be fixed or cleaned by a chimney sweep)
- That there is nothing flammable that is in touch with or close to the flue or the device.



Smoke contains CO (carbon monoxide), so any smoke escape must not be tolerated.

8. TERTIARY COMBUSTION

The three combustion points

The combustion of wood requires a process of primary, secondary, and tertiary combustion to be efficient.

1. Primary combustion

Primary combustion is the initial wood burning at relatively low temperatures. During the primary combustion, large amounts of soot, creosote and gas are produced due to the existence of water in the wood. Creosote, in primary combustion, contains 60% of the potential energy of wood, but it is deposited in the form of soot inside the fireplace and the flue without imparting any heating.

2. Secondary combustion

The combustion chamber is insulated so as to increase the temperature of the core and by providing just the right amount of oxygen necessary to 600°C, the creosote ignites spontaneously. This creates a chain reaction that increases the temperature inside the fireplace from 600°C to about 870°C without having to add any more fuel. This is the secondary combustion.

Thereby, the more proper secondary combustion is achieved the higher temperatures are produced and the less residue is left (gas and particles). The vast majority of secondary combustion is only done in the upper part of the chamber near the outlet of the flue. Thus a large part of the heat that is achieved, is discharged directly through the draft of the flue to the exterior and not in the heating area.

The triple baffle system which delays the smoke together with ARTE's® combustion chamber manage to give us the maximum performance of secondary combustion. The primary's intake air system from the bottom side of the combustion chamber, in cooperation with the secondary's intake air system from the back of the combustion chamber supply uniformly the suitable quantity of preheated air, which together with air curtain of the ceramic glass result in every place of the combustion chamber to receive the proper amount of preheated oxygen (**Pic. 8.1**). This way the whole area of the chamber is converted in a secondary combustion chamber, and thus its performance dramatically increases and inversely gas residue reduces.

3. Tertiary combustion

The tertiary combustion occurs when the coal that remains on the bottom burns in a proper and coordinated way. Coal contains a large amount thermal energy that when used provides a large amount of heat. Proper air flow directly on the coals within such a hot room, results in almost complete consumption and minimizing the amount of ash that is collected on the bottom.

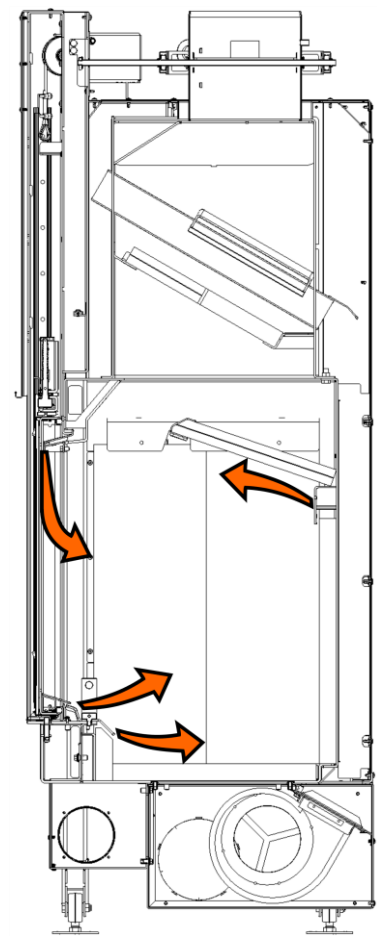

Pic. 8.1

9. CLEANING AND MAINTAINING THE FIREPLACE



When performing maintenance on the fireplace, always protect yourself, using safety goggles and gloves.

9.1. External maintenance

The fireplace surface is painted with heat-resistant paint. It is best kept clean by vacuuming with a soft brush attachment or by wiping with a lint-free cloth. Over a period of time, the painted surface may become slightly grey. A canister of touch-up ARTE ® spray paint should be available from your fireplace supplier. This can be applied - in accordance with the instructions - in just a few minutes. When first firing, after touching up, the fireplace will give off a slight smell as the paint cures. Make sure to ventilate the room well during this phase.

9.2. Internal maintenance



Due to the self-closing door you should be very careful for any accidents during the maintenance of the fireplace.

- Ash disposal

Empty the excess ash as often as necessary in order for the level to remain below the appropriate **(Pic. 9.2.1)**. ARTE® fireplace is designed to produce the least amount of ash, almost 1Kg for every 100Kgs of firewood. It is recommended to constantly maintain a layer of ash with thickness of 1-2 cm at the base of the combustion chamber for added insulation.

Dispose the ash by following these steps:

- ① Open the main door and use a small shovel or a scoop to remove the excess ash
- ② Dispose the ash in a metallic container with a tight lid

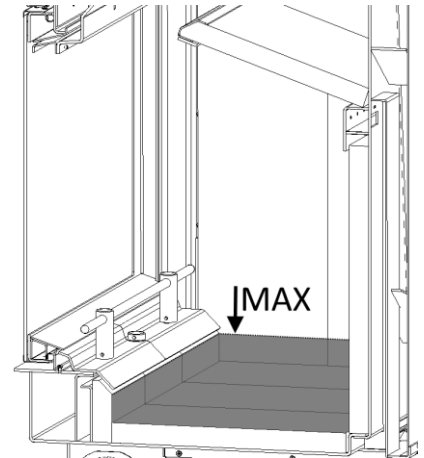

Pic. 9.2.1

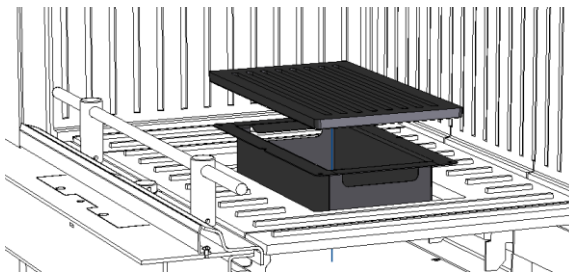

Pic. 9.2.2

If you have a cast iron bottom and ashtray, lift up the cast iron grill from the middle and remove the ashtray **(Pic. 9.2.2)**. Dispose the ash inside a metal bowl with tight lid.

The closed container with the ash should be placed on a nonflammable floor or on the ground, away from flammable materials until the final disposal of the ash. The ash must be stored in a closed container until cooled down, or buried on the ground or dispersed somewhere.



Never empty a fireplace while in use.
Never use your household or shop vacuum cleaner to remove ash from the fireplace. There are special ash vacuum cleaners.
Always remove and dispose of the ash properly.

- Glass

ARTE® MENTOR fireplace has a single ceramic glass in the window of the combustion chamber in order to receive as much heat as possible by radiation. If the fireplace is generally operated at the correct temperature, there should be little or no soot on the glass.

The cleaning procedure must be done when the fireplace is cold as follows:

- With one hand, turn the handle, which is located above the door, to the right and keep the weight of the door with the other hand **(Pic. 9.2.3)**.
- Pull the door outside till the point where the movement stops **(Pic. 9.2.4)**.
- From the resulting opening, the glass can be cleaned internally.
- Follow the same procedure vice versa, in order to secure again the door.

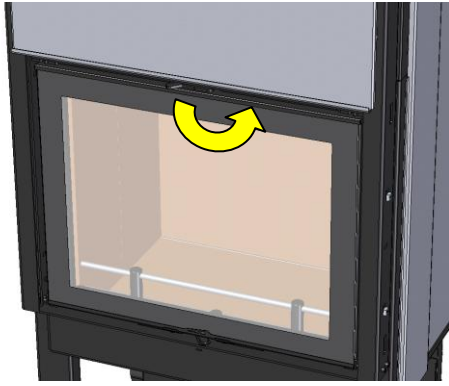

Pic. 9.2.3

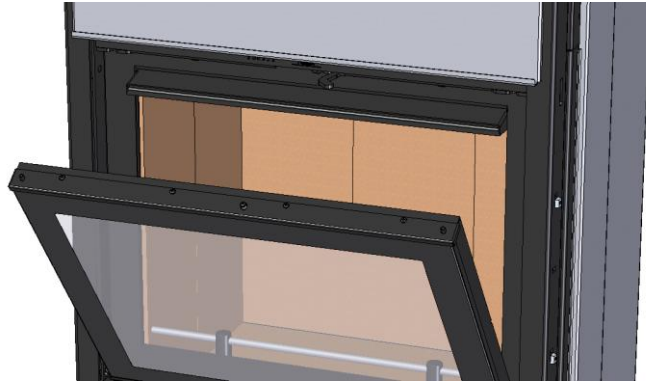

Pic. 9.2.4

For normal cleaning, moisten a paper towel with water and add some ash from the combustion chamber. Rub it over the glass and then clean the glass with clean water and dry it well. For heavier deposits that cannot be cleaned, use glass cleaner, applied when the glass is cold, in accordance with the instructions.

Never use abrasive cleaners on the glass surface.

Reasons for the presence of dirt on the glass:

- ① Firewood is too wet
- ① Logs are too large or not split
- ① Combustion temperatures are too low



To reduce the risk of breaking the glass, avoid striking the glass or slamming the door.

Replace broken glass IMMEDIATELY.

Do not operate the fireplace if the glass in the door is damaged.

If there is a need to replace the glass, it should be replaced with the high temperature ceramic glass supplied by ARTE ®. For more information, please contact your local ARTE ® dealer.

- Gasket

The gasket around the perimeter of the door may harden over a period of time. It should be replaced if it becomes difficult to close the door or if air starts to leak in around the perimeter of the doors, causing the fire to become a little less controllable. An ARTE ® rope gasket kit is available on your local ARTE ® dealer.

- Internal parts that need maintenance

The components that are in the flame route - consisting of the lining vermiculites, the ceramic glass, the vermiculite baffles and the steel baffle - are subject to extreme stress because of the heat produced by the fire. Occasionally, some of these parts may have to be replaced as part of routine maintenance.



Components in the flame route, the gasket and the paint finish are not covered by the warranty.

All of these service parts can be bought from your ARTE ® dealer, and we recommend that damaged parts are replaced as soon as possible to avoid consequential damage.

Should the baffle be distorted by overheating, the fireplace will still function, although its efficiency may be compromised. Please replace it as soon as possible.

Internal wear accelerating factors

- ① Regular overheating
- ① Accumulated soot and ashes

9.3. Cleaning the fireplace and the flue

When wood is burned slowly, it produces tar and other organic vapors, which combine with emitted moisture to form creosote. When the fire is low, the creosote vapors condense in the relatively cool chimney flue. As a result, creosote residue accumulates on the flue lining. When ignited this creosote makes an extremely hot fire, which can destroy the flue/chimney.

Initially, do a monthly check for the presence of soot above the deflector plate and around the outlet flue. If the fireplace suddenly start operating slowly check for intense presence of soot around the flue collar or in the flue / chimney.



The flue should be inspected at least once every two months during the operating season to determine if a creosote buildup has occurred. If creosote has accumulated, it should be removed to reduce the risk of a chimney fire.

Clean the flue/chimney all the way from the fireplace to the flue end point above the house. A good practice is to clean the flue after each operating season and to inspect it prior to the start to ensure that bird's nests or other blockages have not occurred during the off season.

- Chimney sweeping

Inspect the fireplace regularly during the operating season as part of a regular maintenance schedule.

To inspect the chimney, let the fireplace cool completely. Then, remove the baffles, place a mirror in the upper area of the combustion chamber and turn it upwards, in order to inspect the chimney.

Clean the chimney using a brush with the same size and shape as the flue. Run the brush up and down the flue, causing any deposits to fall to the bottom of the fireplace where they can be removed the same way as the ash.

If you cannot inspect or clean the chimney by yourself, contact your local ARTE® dealer or a professional chimney sweep.

If you experience a chimney fire, act promptly and:

- ① Close the air regulation
- ① Evacuate the house
- ① Call the Fire Department

- Annual maintenance

Before the operating season starts, perform a thorough cleaning, inspection and repair:

- ① Thoroughly clean the chimney and flue connector.
- ① Inspect the chimney for damage and deterioration. In case of prefabricated chimney, replace any weak sections. In case of a masonry chimney, have a mason make any needed repairs
- ① Check the ceramic glass for any cracks and replace if needed.
- ① Check if the door is airtight and the handle tight. Fix any problems.

- How to clean the inside parts of ARTE® MENTOR

During the annual visit of your local chimney sweep and during the cleaning of internal parts of the fireplace, it is recommended to remove all internal parts of the combustion chamber to be also cleaned (**Chapter 9.4**).



The cleaning of the fireplace must be done ONLY when the device is cold.

9.4. Internal parts

- Removal of the 1st baffle

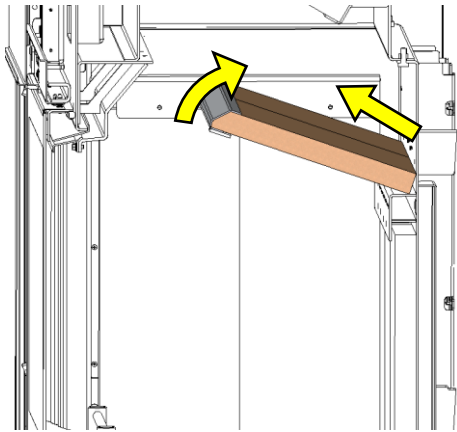

Pic.9.4.1: Lift up the front side and pull outwards.

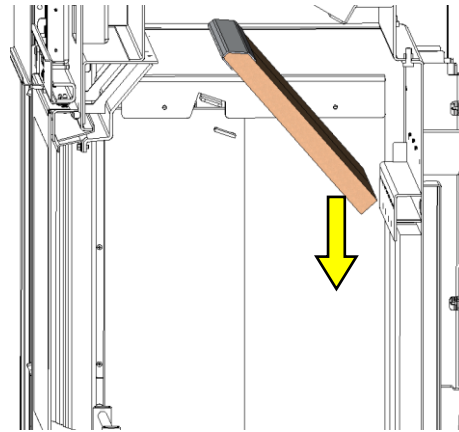

Pic.9.4.2: Remove the baffle by pulling it downwards.

- Removal of the 2nd baffle

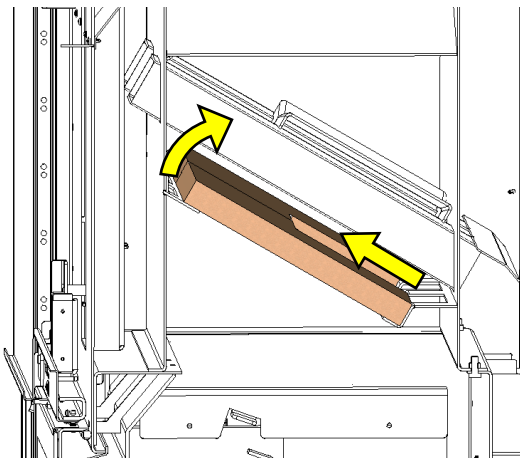

Pic.9.4.3: Select one of the pieces that form the 2nd baffle, lift it up from the front side and pull outwards.

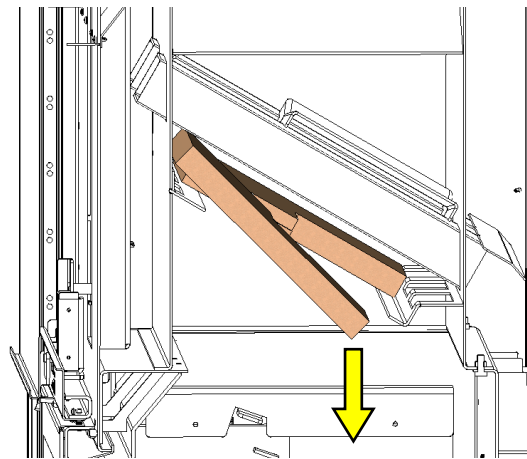

Pic.9.4.4: Remove the baffle by pulling downwards. Repeat the procedure for the rest of the pieces.

- Removal of the 3rd baffle

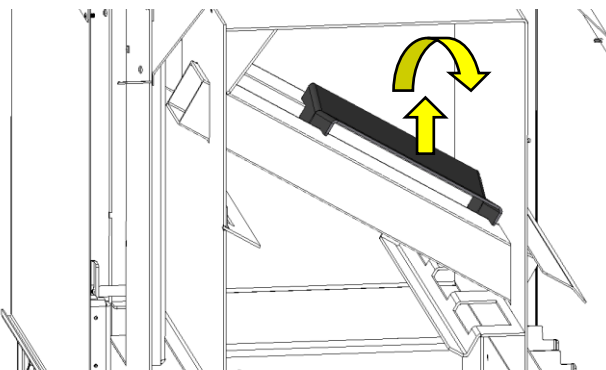

Pic.9.4.5: Push the baffle upwards and rotate it in order to pass through two horizontal pipes.

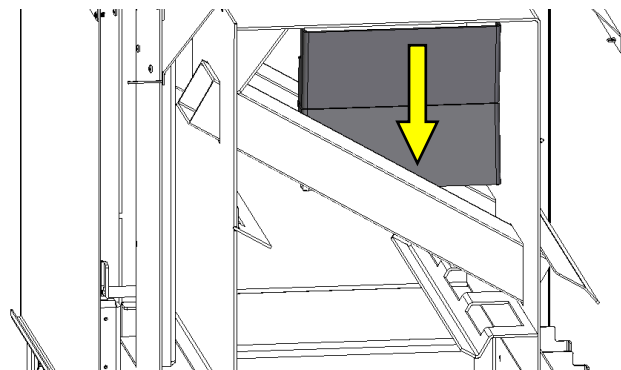

Pic.9.4.6: Remove the baffle by pulling it downwards.

- Removal of side vermiculites

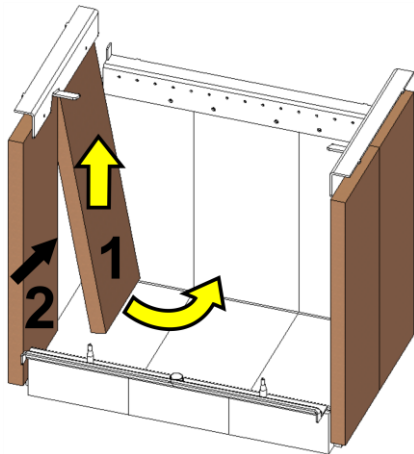

Pic.9.4.7: Remove the 1st baffle (Pic. 9.4.1). Lift up the vermiculite No 1 and then pull it inwards. Slide the vermiculite No 2 backwards, in order to be able to repeat the same procedure as for Vermiculite No 1.

- Removal of back vermiculites

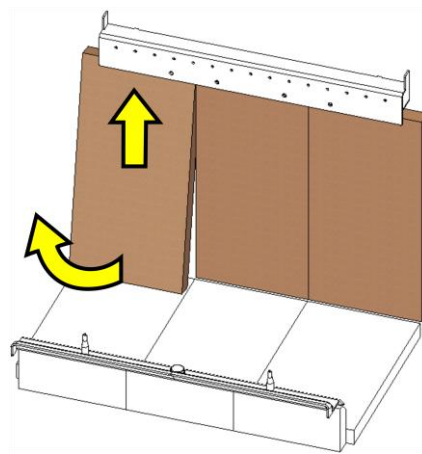

Pic.9.4.8: After the removal of the side vermiculites, lift up the back vermiculite and then pull it inwards.

- Removal of the bottom vermiculites (Floor)

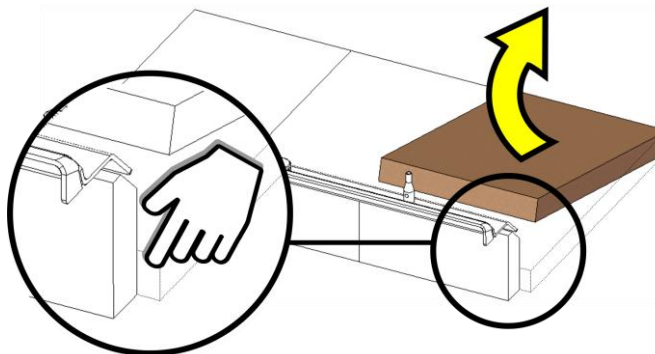

Pic.9.4.9: After the removal of the side vermiculites, lift up the vermiculite and then pull it inwards.

- Removal of the bottom vermiculites (Front side)

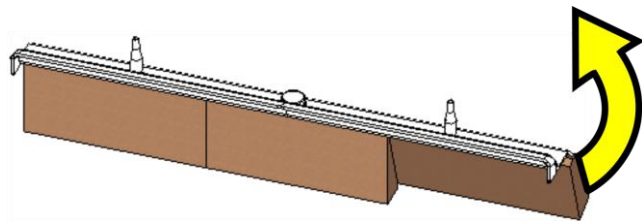

Pic.9.4.10: After the removal of the floor vermiculites, pull the vermiculite slightly right and then pull it inwards, lifting its bottom face upwards.

9.5. Inactive fireplace for prolonged periods

IMPORTANT NOTICE: If the fireplace is not used for some time, clean it thoroughly and let the air control layout slightly open in order to let the air circulate. Ensure that the rainwater cannot infiltrate from the flue. Place a chimney cap that does not completely block the flue.

These actions should ensure there is a slight movement of air through the fireplace, and that the body and combustion chamber remain dry, right into the corners.

Ash that remains in the fireplace, when not in use, can absorb moisture like blotting paper. If moisture settles inside the fireplace, it forms rust which expands the more it settles. This can cause excessive pressure on the fireplace joints, thus causing damage.

NOTE: It is recommended to thoroughly clean the fireplace at the end of the operating season. Adding desiccant in the combustion chamber, such as cat litter, helps absorb moisture during the summer. Make sure to remove it before the beginning of the operating season.

10. TIPS AND TRICKS FOR RESOLVING ISSUES

The wood does not ignite by lighting the fireplace. The fire just smokes. The fire burns out

- ① Open the air supply
- ① You are not using proper kindle
- ① The wood is too wet
- ① The logs are too thick
- ① The ash is over the appropriate limit

Intense smoking in the combustion chamber, intense soot deposition on the glass

- ① Open the air supply
- ① Small quantity of wood
- ① The wood is too wet
- ① The logs are too thick

There is smoke coming out of the fireplace

- ① Check if there is adequate draft into the flue, light a test fire
- ① Make sure there is sufficient air supply



We hope you enjoy many years of carefree warmth with ARTE® MENTOR fireplace. Some initial experimentation with loading and operating techniques will help you decide your normal routine. If you have any problems after this short learning period, please contact your local ARTE® dealer. In case, for any reason, they can't help, please contact us in writing at the address on the back of this manual.



The qualified dealer in your area is available to answer any of your further questions.

11. DIMENSIONS AND TECHNICAL SPECIFICATIONS

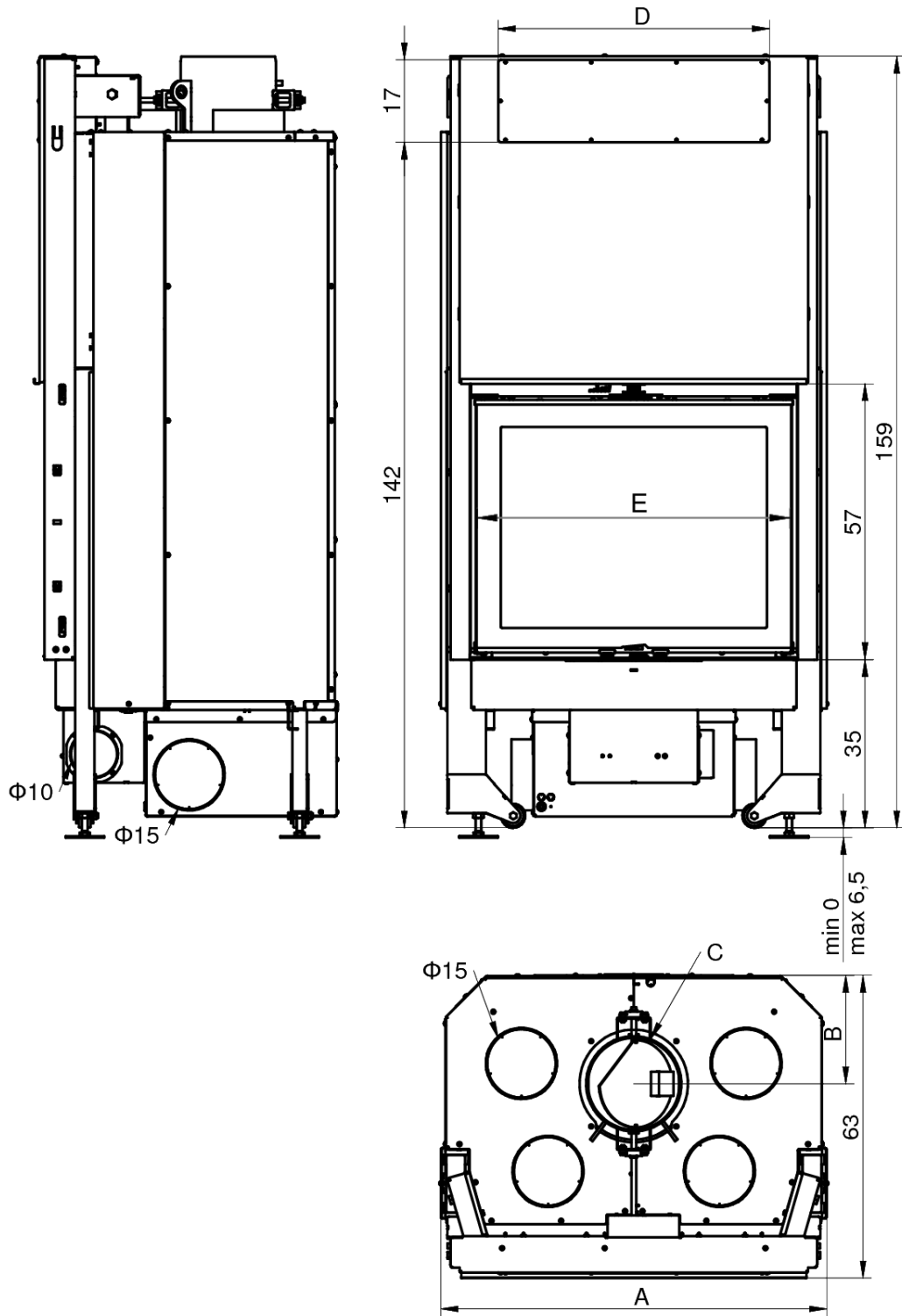

DIMENSION	MODEL			
	MENTOR ST80	MENTOR ST90	MENTOR ST100	MENTOR ST120
A (cm)	80	90	100	120
B (cm)	22,4		25,2	
C (cm)	$\Phi 20$		$\Phi 25$	
D (cm)	56	66	76	96
E (cm)	65	75	85	105

Table 11.1

TECHNICAL SPECIFICATIONS	UNITS	MENTOR ST 80		MENTOR ST 90		MENTOR ST 100		MENTOR ST 120	
		STANDARD	PLUS	STANDARD	PLUS	STANDARD	PLUS	STANDARD	PLUS
*Total heat output	Kcal/h	12900	14600	14200	15500	15500	17200	16800	18500
	kW	15	17	16.5	18	18	20	19.5	21.5
Recommended hourly consumption of firewood	Kg/h	4.2		4.7		5.2		5.7	
Heat output	%	83		82		81		80	
Exhausts temperature	°C	222		225		225		227	
CO emissions (by providing O ₂ at 13%)	%	0.09		0.09		0.09		0.09	
Yield range (minimum - maximum)	kW	9.9 – 21.2	11 – 23.5	9.8 – 22.3	10.8 – 24.8	10.3 – 22.7	11.5 – 25.2	10.9 – 23.8	12.1 – 26.4
Fuel	-	**Wood / Briquette							
Device dimensions (W x D x H)	cm	80/63/160		90/63/160		100/63/160		120/63/160	
Combustion chamber dimensions (W x D x H)	cm	61/36/53		71/36/53		81/36/53		101/36/53	
Flue draft	Pa	12±2							
Heated area	m ²	65 – 175	75 – 185	65 – 195	70 – 205	70 – 210	75 – 220	75 – 240	80 – 250
Weight	Kg	285		310		340		385	
*** External air inlet	cm	Ø 10							
**** Smoke outlet diameter	cm	Ø 20				Ø 25			
**Minimum flue height	m	4							
Minimum heating area	m ²	65		65		70		75	
<p>* The fireplace operates with intermittent combustion technology. In this case intermittent combustion means the normal use of the fireplace, e.g. new firewood is added as soon as the previous are burned, forming a sufficient amount of cinder.</p> <p>**Always use fewer briquettes than wood, cause of different calorific value (Table 2.5.1).</p> <p>*** The section must be increased by 20% each meter above 1 meter.</p> <p>****The internal section of the flue must be increased by 10% per 500m altitude above sea level.</p>									

Table 11.2

12. NOTES

ΕΓΓΥΗΣΗ

Το νέο σας προϊόν συνοδεύεται από διετή εγγύηση, η οποία αφορά και σε όλα τα ηλεκτρικά μέρη, εφόσον υφίστανται τέτοια και η οποία αρχίζει από την ημερομηνία αγοράς του προϊόντος, όπως αυτή θα αποδεικνύεται από το σχετικό φορολογικό παραστατικό.

Η εγγύηση αφορά στην επιδιόρθωση ή αντικατάσταση με νέο ανταλλακτικό μερών του προϊόντος, καλύπτοντας το κόστος των εργασιών επιδιόρθωσης ή αντικατάστασης και των ανταλλακτικών.

Η παρούσα εγγύηση ισχύει υπό την προϋπόθεση της καταβολής του τιμήματος του προϊόντος και την συμπλήρωση και παράδοση του πιστοποιητικού εγγύησης στην ARTE Γ. Καρνούτσος και ΣΙΑ ΟΕ, εντός τριάντα ημερών από την ημερομηνία αγοράς, η οποία θα αποδεικνύεται από την έκδοση του σχετικού παραστατικού.

1.1 Όροι εγγύησης

- Ορθή εγκατάσταση από εξειδικευμένο προς τούτο επαγγελματία
- Χειρισμός του προϊόντος σύμφωνα με τις οδηγίες χρήσης και λειτουργίας του κατασκευαστή
- Διαλείπουσα καύση
- Προστασία από υπερθέρμανση
- Συστηματική συντήρηση (ετήσιος καθαρισμός), του προϊόντος αλλά και του συστήματος απαγωγής καυσαερίων (καπνοσωλήνας – καμινάδα)
- Μη τροποποίηση της δομής του προϊόντος, καθώς ενδέχεται να προκληθεί εσφαλμένη λειτουργία και μόνιμη φθορά.

1.2 Εξαιρέσεις από την εγγύηση

- Ζημιές οφειλόμενες σε γεγονότα ανωτέρας βίας
- Μέρη που υπόκεινται σε φθορά, όπως ενδεικτικά και όχι περιοριστικά, βερμικουλίτες,τσιμούχες και τζάμι
- Ζημιές από καπνό και αιθάλη
- Φυσικός αποχρωματισμός ή αλλοίωση χρωμάτων στην εξωτερική επένδυση
- Ενδεχόμενες ρωγμές στο θάλαμο καύσης, οι οποίες όμως δεν επηρεάζουν την ασφαλή λειτουργία του προϊόντος
- Ζημιές λόγω μη συμμόρφωσης προς τις παρούσες οδηγίες λειτουργίας
- Ζημιές κατά την εγκατάσταση και οφειλόμενες σε αυτήν
- Ζημιές που προκλήθηκαν από κακή μεταφορά, εγκατάσταση ή χρήση
- Ζημιές που οφείλονται σε φυσιολογική φθορά
- Ζημιές που οφείλονται σε χρήση μη γνήσιων ή μη κατάλληλων για το προϊόν ανταλλακτικών

Προκειμένου να ισχύει η εγγύηση θα πρέπει:

- Το προϊόν να λειτουργεί εντός των ευλόγων ορίων χρήσης του
- Οι εργασίες συντήρησης να διενεργούνται συστηματικά, τακτικά και επιμελώς
- Το προϊόν να χρησιμοποιείται μόνο από άτομα που διαθέτουν επαρκείς ικανότητες και κατάλληλη εκπαίδευση
- Ο χρήστης να συμμορφώνεται με τις οδηγίες που περιέχονται στο παρόν εγχειρίδιο

Επίσης, στα πλαίσια της εγγυήσεως δεν περιλαμβάνεται η αποκατάσταση ζημιών ή εξόδων για επενδύσεις ή φθορές που προκλήθηκαν σε πράγματα (κινητά ή ακίνητα) προκειμένου να αντικατασταθεί ελαττωματικό τμήμα του προϊόντος, ενώ τυχόν κόστος μεταφοράς του προϊόντος ή ανταλλακτικού από την εταιρία στον καταναλωτή και το αντίστροφο, ομοίως δεν περιλαμβάνεται στην εγγύηση και δεν βαρύνει την εταιρία.

Στα πλαίσια της εγγυήσεως αφαιρείται από τις υποχρεώσεις της εταιρίας οτιδήποτε περιήλθε εξαιτίας της ζημίας στον καταναλωτή από οποιαδήποτε πηγή, όπως ενδεικτικά και όχι περιοριστικά, τυχόν αποζημίωση λόγω ασφάλισης ή άλλης συμφωνίας.

1.3 Ευθύνη

Ρητά δηλώνεται δια του παρόντος ότι η ARTE δεν φέρει οποιαδήποτε ευθύνη, αστική ή άλλου είδους, για ατυχήματα που ενδέχεται να προκληθούν λόγω της ολικής ή μερικής μη συμμόρφωσης προς τις προδιαγραφές και οδηγίες χρήσης του προϊόντος.

Ομοίως δεν φέρει ευθύνη οποιουδήποτε είδους απορρέουσα από τη μη προβλεπόμενη χρήση της συσκευής, από τον εσφαλμένο χειρισμό της από τον χρήστη, από μη εξουσιοδοτημένες τροποποιήσεις και/ή επισκευές ή από τη χρήση μη αυθεντικών ή ακατάλληλων ανταλλακτικών για το συγκεκριμένο προϊόν.

WARRANTY

Your new product is accompanied by a two-year warranty, which applies to all electrical parts, if there are any, starting from the date of purchase of the product, as evidenced by the relevant financial document.

This warranty covers the repair or replacement with new spare parts of the product, covering both the cost of mending or replacement and the spare parts.

This warranty is valid under the condition that the price of the product has been paid and the warranty certificate has been completed and delivered to ARTE G. KARNOUTSOS and CO General Partnership, within thirty days from the date of purchase, as evidenced by the issue of the relevant document.

1.1 Terms of Warranty

- Proper installation by a qualified professional
- Operating the product as indicated by the manufacturer's operating and usage instructions
- Intermittent combustion
- Overheat protection
- Regular maintenance (annual cleaning), of the product and the exhaust system (flue - chimney)
- No modification of the structure of the product, as this may cause malfunction and permanent damage.

1.2 Exceptions to the warranty

- Damage due to force majeure events
- Parts subject to wear, such as, but not limited to, vermiculites, seals and glass
- Damage from smoke and soot
- Natural discoloration or color erosion of the exterior coating
- Possible cracks in the combustion chamber, which do not affect the safe operation of the product
- Damage due to non-compliance with the operating instructions
- Damage during and due to installation
- Damage caused by poor transportation, installation or use
- Damage due to normal wear
- Damage due to the use of non-genuine or non-appropriate spare parts

The warranty is valid when:

- The product operates within the limits of reasonable use
- Maintenance is carried out regularly and thoroughly
- The product is used only by individuals with sufficient skills and appropriate training
- The user must comply with the instructions contained in the present manual

Furthermore the warranty does not include damage restoration or investment expenses or damage to parts (movable or immovable) in order to replace a defective part of the product, and any costs caused by transportation of the product or replacement part from the company to the consumer and vice versa, is likewise not included in the warranty and does not burden the company.

As part of the warranty, anything that has been received by the consumer due to damage from any source, is deducted by the company's obligation, including but not limited to, any compensation due to insurance or other agreement.

1.3 Responsibility

It is hereby expressly stated that ARTE does not bear any accountability, civil, criminal or other, for accidents that may be caused by total or partial non-compliance with the product specification and instructions.

Likewise, ARTE does not bear any kind of responsibility arising from the improper use of the appliance, its incorrect operating by the user, unauthorized modifications and / or repairs, or the use of non-genuine or non-appropriate replacement parts for this particular product.

1.4 Responsibility on installation

The responsibility for the work required to install the product is not accountable to ARTE. This work burdens the professional who is responsible to examine the flue pipe and the air inflow and to decide whether the proposed installation solutions are feasible for the space in question. All standards, as well as national and European legislation, as they apply to each local jurisdiction, are required.

1.4 Ευθύνη σχετικά με την εγκατάσταση

Η ευθύνη για τις εργασίες που απαιτούνται για την εγκατάσταση του προϊόντος δεν βαρύνει την ARTE. Οι σχετικές εργασίες επιβαρύνουν τον εξειδικευμένο προς τούτο επαγγελματία, ο οποίος καλείται να ελέγξει τον καπνοσωλήνα και την εισροή αέρα και να αποφανθεί κατά πόσον οι προτεινόμενες λύσεις εγκατάστασης είναι εφικτές για τον εκάστοτε χώρο. Απαιτείται η τήρηση όλων των προτύπων, καθώς και της εθνικής και ευρωπαϊκής νομοθεσίας, όπως αυτές ισχύουν αναλόγως της κάθε φορά τοπικής αρμοδιότητας.

1.5 Τακτική και έκτακτη συντήρηση

Οι εργασίες τακτικής ή έκτακτης συντήρησης στο συγκεκριμένο προϊόν, διενεργούνται από εξειδικευμένο προς τούτο επαγγελματία, διαφορετικά η παρούσα εγγύηση δεν ισχύει.

1.6 Χρήση

Η χρήση της συσκευής πρέπει να γίνεται σύμφωνα με όλα τα πρότυπα ασφαλείας που έχουν θεσπισθεί βάσει των σχετικών νόμων που ισχύουν στον τόπο εγκατάστασης του προϊόντος, καθώς και σύμφωνα με τις οδηγίες που περιέχονται στο παρόν εγχειρίδιο, διαφορετικά η παρούσα εγγύηση δεν ισχύει.

1.7 Διαθεσιμότητα τεχνικών υπηρεσιών και ανταλλακτικών

Σε περίπτωση επιδιόρθωσης ανταλλακτικού ή του προϊόντος ή σε περίπτωση αντικατάστασης ανταλλακτικού, η εμπορική εγγύηση δεν ανανεώνεται εκ νέου και η διάρκειά της είναι αυτή που απομένει μέχρι τη συμπλήρωση της αρχικής διάρκειας της παρεχόμενης εγγυήσεως.

Η εταιρία μας εγγυάται ότι ακόμα και αν δεν καλύπτεται αυτό από την εγγύηση, αυτή θα διαθέτει κατάλληλο προσωπικό για παροχή τεχνικών υπηρεσιών ως και επαρκή ποσότητα ανταλλακτικών, με την αντίστοιχη κατά περίπτωση χρέωση, για δέκα έτη από την αγορά του προϊόντος.

1.8 Νόμιμη εγγύηση

Η παρούσα εγγύηση παρέχεται ανεξάρτητα από οποιαδήποτε μη εξαιρούμενη νομική εγγύηση ή σχετική εθνική νομοθεσία, που ισχύει, όπως ενδεικτικά και όχι περιοριστικά τα σχετικά άρθρα του ΑΚ, το ν. 2251/1994, την ΥΑ Ζ1/2013, τις οδηγίες 2011/83/ΕΕ, 1999/44/ΕΚ, όπως αυτές ισχύουν, ως και κάθε άλλο σχετικό νομοθετικό κείμενο, το οποίο κατά περίπτωση εφαρμόζεται και δε θα επηρεάσει με οποιονδήποτε τρόπο τα δικαιώματα του καταναλωτή που απορρέουν από τις σχετικές νομοθετικές διατάξεις.

1.5 Regular and emergency maintenance

Regular or emergency maintenance work on this product is carried out by a qualified professional, otherwise this warranty does not apply.

1.6 Usage

The appliance must be used in accordance with all safety standards established under the relevant laws in force at the place of installation and the instructions contained in this manual, otherwise this warranty does not apply.

1.7 Availability of technical services and replacement spare parts

In case of spare parts or product repair or spare parts replacement, the commercial warranty can not be renewed again and its duration is the one remaining until the completion of the initial term of the supply warranty.

ARTE guarantees that, even if this is not covered by the warranty, it will still provide qualified technicians to provide technical services as well as a sufficient quantity of spare parts, with the corresponding charge, for ten years after the purchase of the product.

1.8 Legal Warranty

This warranty is provided regardless of any non-exempt legal guarantee or relevant national legislation in force, including but not limited to the relevant articles of the Civil Code, n. 2251/1994, MD Z1 / 2013, Directives 2011/83 / EU , 1999/44 / EC, as applicable, as well as any other relevant legal text, which shall be applied on a case-by-case basis and will not affect in any way the consumer's rights deriving from the relevant legal provisions.

ΣΗΜΕΙΩΣΕΙΣ | NOTES

S/N:

Εργοστάσιο - Έδρα

Προέκταση Στρ. Μακρυγιάννη
Εύοσμος, Θεσσαλονίκη

Factory - Head Offices

Ext. Gen. Makrygianni Str.
Evosmos, Thessaloniki, Greece

Αλληλογραφία

T.K. 56410 | T.Θ. 40124
Σταυρούπολη, Θεσσαλονίκη

Mail

P.C. 56410 | P.O. Box 40124
Stavroupoli, Thessaloniki, Greece

 +30 2310 684 148

 +30 2310 684 149

 info@arte-fireplace.com

 www.arte-fireplace.com

